

# The order of operations and A/ $\bar{A}$ interactions

Elise Newman\*

October 25, 2023

## Abstract

Double object constructions provide an ideal context in which to investigate interactions between multiple instances of movement. With two internal arguments, we can construct scenarios where one A-moves and another  $\bar{A}$ -moves, such as in the passive wh-question *What was Sue given?*. Holmberg et al. (2019) observe that in many languages (e.g. Norwegian) which otherwise permit either object of a double object construction to A-move to subject position, a restriction emerges when the indirect object wh-moves: the indirect object must also A-move (e.g. *Who was given a book?*). One cannot pronounce an indirect object wh-question in a clause where the direct object A-moves instead (*\*Who was a book given?*). In this manuscript, I observe that this restriction is only found in languages which otherwise permit the indirect object to A-move. In languages such as Greek, which have no indirect object passives, indirect objects can freely wh-move in a direct object passive, and thus do not exhibit the same restriction as Norwegian. I propose that this restriction comes about in languages such as Norwegian but not Greek due to the timing of wh-movement relative to A-movement within *v*P. Indirect objects wh-move through the position that controls A-movement early, blocking a direct object from A-moving, so long as the indirect object can A-move itself. The analysis features a *smuggling* approach to passives of ditransitives (Collins, 2005) and an economy condition like van Urk & Richards' (2015) *Multitasking*, which jointly predict the order of operations that gives rise to the wh-movement restriction observed in Norwegian.

**Keywords:** A-movement,  $\bar{A}$ -movement, Merge, double object constructions, passives, locality

## Contents

<b>1</b>	<b>Introduction</b>	<b>3</b>
<b>2</b>	<b>Holmberg et al. (2019)</b>	<b>6</b>

---

\*I would like to thank Claire Halpert, Sabine Iatridou, David Pesetsky, Norvin Richards, Michelle Sheehan, the members of the LASER team (Kenyon Branan, Tom McFadden, Sandhya Sundareshan, Rob Truswell, Hedde Zeijlstra), and the audiences of MIT Ling Lunch and the LASER Kickoff Workshop for their expertise, feedback, and encouragement on this project. A special thanks goes to Enrico Flor, the Narayanan family, Johannes Norheim, the Öztürk family, and Giovanni Roversi for offering linguistic judgments and commentary. This research was funded by the Arts & Humanities Research Council (UKRI), award ref. AH/V002872/1 and title "Locality and the argument-adjunct distinction: Structure-building vs. structure-enrichment". All mistakes are my own.

<b>3</b>	<b>Merge features and clause structure</b>	<b>10</b>
3.1	The logic of Merge features . . . . .	10
3.1.1	A note on locality and anti-locality . . . . .	13
3.2	Feature-checking with actual functional projections . . . . .	15
3.2.1	Subjects and wh-movement . . . . .	15
3.2.2	Ditransitives, passives, and smuggling . . . . .	18
<b>4</b>	<b>Explaining the DOMA</b>	<b>24</b>
4.1	Languages with symmetric passives . . . . .	31
4.2	Languages with no indirect object passives . . . . .	34
4.3	Apparent counterexamples . . . . .	39
<b>5</b>	<b>Conclusion</b>	<b>41</b>
<b>A</b>	<b>Some additional notes on feature-checking</b>	<b>47</b>
A.1	A note on improper movement . . . . .	47
A.2	Feature-checking and the functional hierarchy . . . . .	48
A.3	More on head movement . . . . .	48
<b>B</b>	<b>Italian</b>	<b>49</b>

Table 1: Abbreviations and glossing conventions not otherwise covered by the Leipzig glossing rules

DO	direct object
IO	indirect object
A	augment
CL	clitic
FV	final vowel
N-ACT	non-active
OM	object marker
RS	relative suffix
SM	subject marker

# 1 Introduction

This paper is concerned with the time at which different syntactic operations occur in the verbal domain, particularly those that target its *edge*. The edge of  $vP$  is often proposed to host several kinds of Merge: external Merge of an argument, A-movement of an argument (Legate, 2003; Sauerland, 2003; Longenbaugh, 2019), and successive cyclic  $\bar{A}$ -movement of a wh-phrase (Chomsky, 1986).

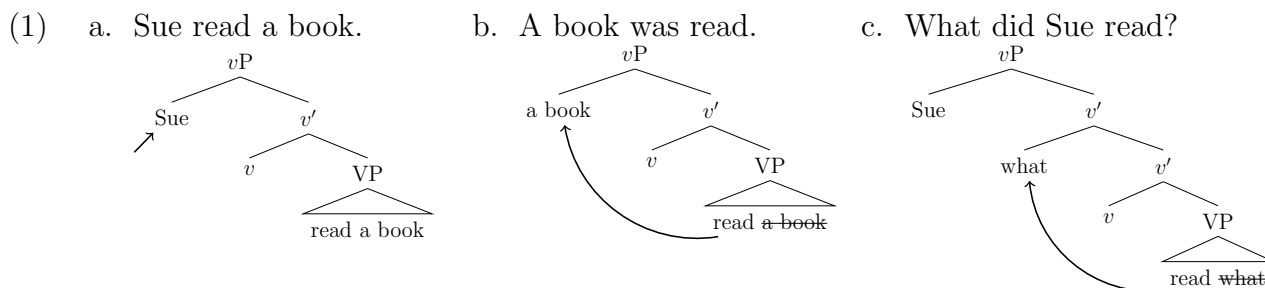

In English object wh-questions like (1c), the external argument always controls subject agreement rather than the moving wh-phrase (*What I am/\*is*). Somehow, the  $\varphi$ -probe on T must therefore be able to selectively target the external argument despite the fact that two phrases occupy Spec  $vP$  at the time T is merged: the external argument and the wh-object. Agreement with the external argument in (1c) cannot result from an inability of wh-phrases to control agreement. Passive contexts do permit moving wh-phrases to control subject agreement, as in (2).

(2) Which books **were** read by Sue?

The comparison between (1c) and (2) leads us to the following general question: in cases where the edge of  $vP$  is occupied by two elements, one of which has wh-moved there, which one is visible to higher attractors/probes such as those responsible for subject agreement? Are there any contexts in which a wh-phrase blocks another argument from acting as the surface subject of the clause? Here and throughout, I use the term ‘subject’ to refer to the element that controls subject agreement and surfaces in subject position, regardless of thematic role.

One context that fits this description has been called the “Double Object Movement Asymmetry” by Holmberg et al. (2019), who observe this effect in a variety of languages such as Norwegian, North-West British English, Zulu, Lubukusu, Xhosa (Visser, 1986), Swati (Woolford, 1995), Haya (Duranti & Byarushengo, 1977), Fuliiru (Van Otterloo, 2011), Sotho (Morolong & Hyman, 1977), and Tswana (Creissels, 2002). In (3), we see that Norwegian normally permits either a direct object or an indirect object of a double object construction to be the subject of a passive clause. However, if the indirect object wh-moves, the direct object is blocked from being the subject of the passive (4a). Indirect object wh-questions built from passives are only grammatical if the indirect object is the surface subject (4b)<sup>1</sup>.

(3) *Norwegian symmetrical A-movement* (Haddican & Holmberg, 2015, ex. 2, p. 146)

<sup>1</sup>Here and throughout, I use the Leipzig glossing rules, except where indicated in Table 1.

- a. Jeg ble gitt \_ Paralgin Forte.  
 I was given Paralgin Forte  
 ‘I was given Paralgin Forte.’
- b. Lånet ble gitt meg \_.  
 the.loan was given me  
 ‘The loan was given to me.’

(4) “**Double object movement asymmetry**” (DOMA): the direct object cannot be the subject of a passive in which the indirect object has wh-moved (subjects in bold) (Holmberg et al., 2019, ex. 5d,a, p.680)

- a. \*Hvem ble **boka** gitt \_ \_?  
 who was the.book given  
 intended: ‘To whom was the book given?’ *DO=subject; IO=wh-phrase*
- b. **Hvem** ble gitt \_ boka?  
 who was given the.book  
 ‘Who was given the book?’ *IO=subject; IO=wh-phrase*

The reverse pattern is not observed: indirect objects are allowed to be the subject of the passive, whether or not the direct object has wh-moved (5).

- (5) (Holmberg et al., 2019, ex. 5b,c, p.680)
- a. Hvilken bok ble **Jon** gitt \_ \_?  
 which book was Jon given  
 ‘Which book was John given?’ *IO=subject; DO=wh-phrase*
- b. **Hvilken bok** ble gitt Jon \_?  
 which book was given Jon  
 ‘Which book was given to Jon?’ *DO=subject; DO=wh-phrase*

I propose that the restriction in (4a) comes about because of the timing of indirect object wh-movement relative to direct object A-movement in a passive. If the indirect object wh-moves to Spec *vP* first, as schematized in (6), it checks not only the feature specified for wh-elements, but that which licenses A-movement as well, thus blocking the direct object from raising to that position. The result is therefore an indirect object passive. I will argue that the structure of ditransitives and an economy condition on the order of operations conspire to enforce the order of operations in (6), which explains the restriction in (4a).

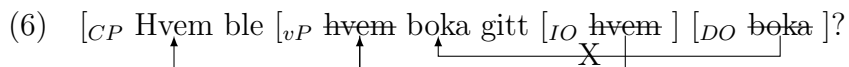

This approach to the DOMA is motivated by its distribution across languages. All of the languages discussed by Holmberg et al. (2019) as exhibiting the DOMA have a common property: both the direct and indirect objects are viable subjects of passives. However, not every language exhibits the DOMA. Greek, for example, permits direct objects to be passive subjects in indirect object wh-questions, unlike Norwegian.

- (7) Greek doesn’t restrict indirect object wh-movement in passives

- a. Tinos dhothike to vivlio?  
 who.GEN gave.N-ACT.3SG the book.NOM  
 ‘Who was the book given to?’ (Anagnostopoulou, 2003, ex.308a, p. 221)

A difference between Greek and Norwegian is that Greek indirect objects are *not* permitted to be the subject in a passive clause – Greek only has direct object passives<sup>2</sup>. Languages that pattern like Greek both with respect to indirect object passives and the DOMA include German, Spanish, Tamil, and Turkish, and are discussed in §4.2.

(8) *Greek asymmetric passives*

- a. To vivlio tis charistike tis Marias.  
 the book.NOM cl.GEN award.N-ACT the Maria.GEN  
 ‘The book was awarded to Mary.’ (Anagnostopoulou, 2003, ex. 33, p. 22)
- b. \*I Maria stalthike to grama.  
 the Maria.NOM sent.N-ACT.3SG the letter.ACC  
 intended: ‘Mary was sent the letter.’ (Anagnostopoulou, 2003, ex. 10a, p. 11)

This difference across languages is expected on the present approach: wh-phrases can only block another argument from being the subject of the clause if they themselves are suitable subjects. An expression that normally can’t be the subject of a clause cannot suddenly become one by being generated as a wh-phrase. Thus, only wh-indirect objects in languages with indirect object passives should be able to bleed a direct object passive, as is observed in DOMA-exhibiting languages.

An outline of the paper is as follows: §2 discusses Holmberg et al. (2019), who propose that the DOMA comes about because of universal constraints on wh-movement. I show that their approach undergenerates by predicting the DOMA in languages like Norwegian, but failing to account for its absence in languages like Greek, thus motivating the need for the present approach.

§3 outlines a theory about how different Merge operations are expected to interact in *vP*, and looks at the structures/derivations of both mono-transitive and ditransitive clauses through this lens. An important consequence of this section is that it motivates a *smuggling* derivation for passives of double object constructions (Collins, 2005, shown in (9)). On this approach, VP must move to Spec *vP* in order to license a direct object passive – if VP stayed in situ, the indirect object would c-command the direct object and block the direct object from raising, due to Relativized Minimality (Rizzi, 1990).

- (9) Smuggling: VP raises to Spec *vP*, bringing the direct object to a position not c-commanded by the indirect object

---

<sup>2</sup>Note that Greek *direct* object passives also differ from Norwegian’s in that they show a dative intervention effect: they require the indirect object to either be clitic doubled or wh-moved when the direct object A-moves (see Anagnostopoulou 2003 for more discussion). The requirement for the clitic in (8a) does not affect the larger proposal here, however.

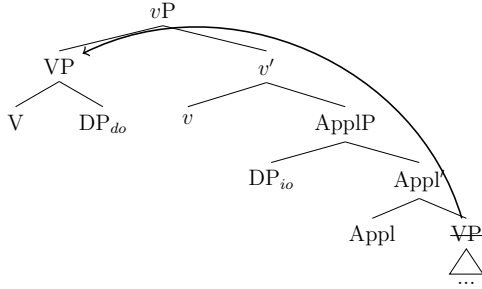

§4 shows how the logic of feature-checking established in §3, in the context of passives of double object constructions in languages like Norwegian but not Greek, predicts the DOMA and its distribution across languages. An economy principle like that proposed by van Urk & Richards (2015) (but revised, shown in (10)), is proposed to constrain the order of operations and derive the DOMA. This economy condition balances competing desires to check as many features as early as possible, while also using every element in the numeration. Specifically, it predicts that indirect object wh-movement must precede VP-movement to Spec *v*P, and thus must precede the time at which the direct object may be considered for A-movement.

(10) *Weak economy*

At every step in a derivation, if two operations A and B are possible, and A checks more features than B, the grammar prefers A, *unless* doing B would check a subset of the features checked by A. In the latter case, the grammar optionally allows A or B.

§5 concludes.

## 2 Holmberg et al. (2019)

I have suggested that we should view the puzzle of the DOMA as evidence for the possibility that wh-phrases may bleed subject-hood of another argument, by moving through the position that introduces external arguments at a particular time in the derivation. This possibility is motivated by the generalization that only languages whose indirect objects can be passive subjects exhibit the DOMA (which will be shown in Sections 4.1-4.2). However, there is an alternative way of viewing the puzzle, taken up by Holmberg et al. (2019), which treats the DOMA as evidence for constraints on wh-movement from certain contexts. I will detail their analysis now and show why the present approach is needed.

Holmberg et al. (2019) assume firstly that passivization precedes wh-movement. With this assumption, the ungrammaticality of (11a) is interpreted as evidence for a restriction on wh-moving the indirect object from a clause in which the direct object has already raised to subject position. To explain this restriction, they propose a modified theory of phase impenetrability combined with a theory of contextually determined phase-hood. Together, these assumptions treat the observed restriction in (11a) as evidence for a problem with the derivation in (11b).

(11) a. \* $DP_{io,wh}$   $DP_{do}$  verb-PASS.

b. Holmberg et al. (2019): Can't wh-move an indirect object past a passivized direct object

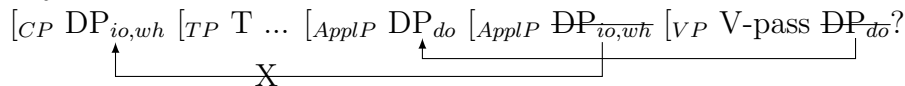

The ingredients of their theory are in (12) and (13). First they adopt the structures in (12) as the two kinds of ditransitive clauses available to languages. Second, they assume a stronger version of the Weak PIC, in which only the highest specifier of a phase head is accessible to wh-movement. Lastly, they assume that different heads may be phases in active vs. passive contexts; the highest argument introducer assumes phase status in each case. As a result, *v* is proposed to be a phase head in active clauses, because it introduces the transitive subject, while *Appl/V* is proposed to be a phase head in passive clauses, depending on the ditransitive construction under consideration<sup>3</sup>.

(12) The two active ditransitive structures, phase head is *v* (in bold)

a. Double object construction (e.g. *Sue gave the cat a treat.*)

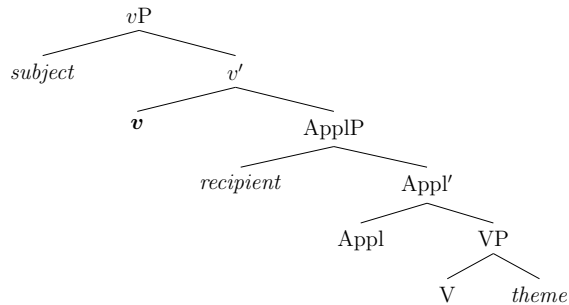

b. Prepositional dative construction (e.g. *Sue gave a treat to the cat.*)

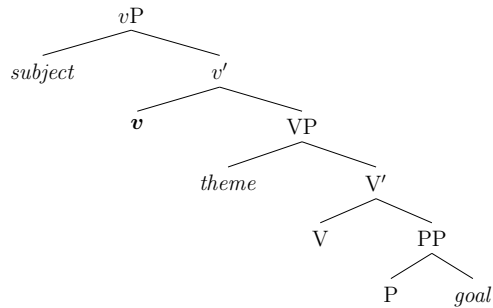

(13) a. Weak PIC/PIC2 (Chomsky, 2001): Given a structure  $[_{ZP} Z \dots [_{XP} X [_{HP} \alpha [H YP]]]]$  where H and Z are phase heads, the domain of H is not accessible to operations at ZP; only H and its edge are accessible to such operations.

i. Revision (Aldridge, 2004, 2008; Bošković, 2016): The edge of a phase is the outermost specifier of the phase head.

b. Flexible phase theory (Holmberg et al. (2019) example 30, p. 690, based on Bošković 2015, 617):  $\alpha$  is the head of a phase Ph making up a thematic domain if and only if  $\alpha$  is the highest head introducing an argument in Ph.

(14) The two passive ditransitive structures, phase head is *Appl/V* (in bold)

a. Double object construction

<sup>3</sup>Aspects of this proposal are consistent with McGinnis (2001a,b), who likewise appeals to the phasal status of ApplP to explain properties of passives of ditransitives.

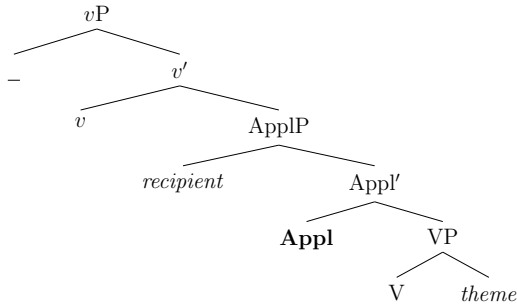

b. Prepositional dative construction

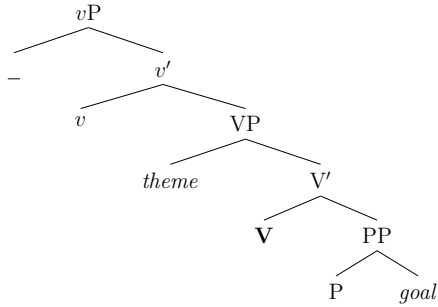

Finally, they propose that direct object passives in the double object construction are derived by raising the direct object past the indirect object to the edge of ApplP (shown in (15)). A direct object passive in a double object construction thus makes the recipient an inner specifier of the ApplP phase, which is inaccessible to *wh*-movement. The proposed restriction on indirect object *wh*-movement from a direct object passive is analogous to Coon et al. (2014)'s proposed restriction on subject *wh*-movement in Mayan transitive clauses, following Aldridge (2004)'s approach to related facts in Austronesian. Importantly, they propose that an Anti-locality constraint keeps the recipient stuck as the inner specifier: it cannot raise past the theme to create a new, outer specifier of ApplP. This Anti-locality constraint follows naturally if we assume in general that once some element has merged with a (projection of a) head, it cannot remerge with a projection of the same head (cf. Abels's 2003 Comp-to-Spec Anti-locality).

- (15) Direct object passive of a double object construction: blocks *wh*-movement of the recipient

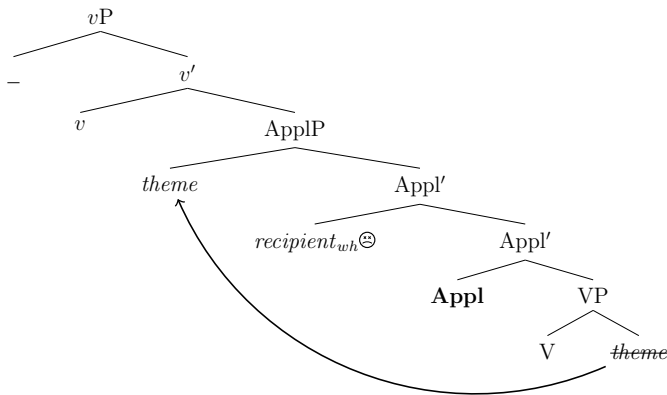

This approach faces two main empirical challenges. First, their analysis predicts that every language with direct object passives of double object constructions should exhibit the DOMA.



If (15) represents the only way to form a direct object passive of a double object construction, wh-movement of an indirect object in that context should be universally banned. However, Sundaresan (2020) shows that this prediction is not borne out in German and Tamil. Furthermore, §4.2 discusses additional counterexamples from Greek, Turkish, and Spanish, all of which have direct object passives of double object structures, but lack the wh-movement restriction on indirect objects in those contexts.

The second empirical challenge pertains to the behavior of wh-movement from prepositional dative constructions. In (16), we can see that making the indirect object a prepositional phrase obviates the DOMA, showing that passives of prepositional dative constructions do not exhibit the trapping effect proposed for double object constructions.

(16) PP-IOs can wh-move in the passive

a. **To** whom was the book given?

(45) **Til** hvem ble boka gitt?  
to who was book.the given

‘To whom was the book given?’

*Norwegian* (Johannes Norheim, p.c.)

In the passive of a prepositional dative, their theory requires V to be the phase head given that it introduces the theme, and no higher head introduces any arguments. However, if this is true, the prepositional phrase must move to the edge of VP in order to wh-move. Doing so, however, would violate Comp-to-Spec Anti-locality: no feature can license movement from the complement of some head to edge of that same head (Abels, 2003). Thus, direct object passives should block PP-indirect object wh-movement as well, contrary to fact.

(17) Pied-piping faces an Anti-locality problem

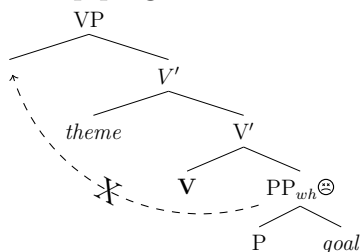

In sum, Holmberg et al.’s theory predicts that every language’s direct object passives (regardless of which ditransitive structure is used) should block recipient wh-movement. However, we find that only some languages exhibit the DOMA, and only in the double object construction, not the prepositional dative construction. While it may be possible to reconcile these facts with Holmberg et al.’s theory, for instance by positing additional covert structure in certain contexts, or accepting parametric variation within phase theory, I propose that these facts are better explained by an alternative approach. The proposed alternative approach focuses on morphosyntactic properties of indirect objects in different languages/contexts, rather than the edge properties of different clause types.

If we instead treat the DOMA as a blocking effect, as I propose that we do (wh-indirect objects block direct objects from becoming the subject), both the distribution of the DOMA across languages and the behavior of wh-movement in prepositional datives is explained straightforwardly – only indirect objects that look like DPs and can act like subjects in other contexts should ever block a direct object passive. Thus, we expect to see the DOMA in languages and

constructions where the indirect object is a plausible subject but not otherwise. The languages of §4.2 do not have indirect object passives and thus do not exhibit the DOMA. Prepositional phrases don't control subject agreement, so prepositional dative constructions also don't exhibit the DOMA.

The strength of the present approach is therefore that it capitalizes on the properties of languages we can see. Whether a language has indirect object passives is easy to diagnose. Whether a moving phrase has overt case morphology/prepositions attached to it is transparently observable. The theory that I outline in the coming sections predicts that a wh-moving indirect object that looks like a DP should become the subject if there is no transitive subject, if the language typically permits it to become a subject in the first place.

A child trying to figure out whether their language has the DOMA therefore only needs to know two facts about their language: 1) whether it has indirect object passives, and 2) what DPs look like, in order to generalize to wh-movement in passives. In what follows, I present a theory of the timing of passivization and wh-movement in double object constructions that makes sense of the facts not covered by Holmberg et al.

### 3 Merge features and clause structure

To explain the DOMA, I propose we take up a different description of the phenomenon compared to Holmberg et al. (2019). They suggest that the DOMA is a restriction on wh-movement of the indirect object whenever the direct object is the passive subject. By contrast, I suggest that the DOMA is a restriction on direct object raising whenever the indirect object is a wh-phrase.

I argue that such a restriction falls out of properties of feature-checking in the verbal domain, when we take into account the features needed for clause-building, A-movement and  $\bar{A}$ -movement to the edge of  $vP$ . To show this, I will first outline some previously motivated assumptions about clause construction from a feature-driven perspective, and show how they can be leveraged to predict which argument becomes the surface subject in different contexts. Then I will propose a modified version of derivational economy, which, when applied to this system, predicts the DOMA.

#### 3.1 The logic of Merge features

This section provides an overview of my framework assumptions, which are drawn predominantly from Chomsky (1995) and its extensions found in Müller (2010), Preminger (2014), van Urk & Richards (2015), Longenbaugh (2019) and Newman (2021).

The theory takes as a starting point the standard minimalist assumption that there is no formal difference between the operations involved in external Merge, A-movement, or  $\bar{A}$ -movement: they are all instances of the same operation *Merge*. Assuming likewise with Chomsky (1995) that something must tell the derivation which Merge operations to employ, I will be representing Merge as a response to features on heads. The notation for the features driving Merge that I adopt is that of Müller (2010) and Longenbaugh (2019), shown in (18b). Replacing [X] with, for example, [D], [wh], [V], etc. yields Merge features which drive structure-building of various kinds.

(18) Framework assumptions/proposals:

- a. All Merge (external Merge, A-movement,  $\bar{A}$ -movement) is feature driven (Chomsky, 1995).
- b.  $[\cdot X \cdot]$  = an instruction to Merge with an element bearing X

The feature notation in (18b) is very generic – it doesn’t make reference to the kind of Merge required to check a given Merge feature. One might imagine that some Merge features have, in addition to a specification for the kind of element which may check it, a requirement to be checked by internal rather than external Merge (for example by requiring agreement with the merged element). However, whether or not some features place additional stipulations on the kind of Merge checking them is not crucial for the present proposal, so I will continue to use the notation in (18b) for any kind of Merge<sup>4</sup>.

Having established what the features involved in Merge look like, we now turn to the conditions on their satisfaction. Suppose, for example, that a head has two features on it:  $[\cdot F \cdot]$  and  $[\cdot G \cdot]$ . Questions now arise pertaining to the order in which these features may be checked, the number of operations required to check them, and what happens if they never get checked. Following Longenbaugh (2019), I assume that the order of feature-checking is only subject to economy considerations (19a): neither UG nor the lexicon impose any particular requirements for some feature to be checked before another (though the resulting structure is subject to interface considerations, which might filter out some derivations). Moreover, I follow (Preminger, 2014; Longenbaugh, 2019) in assuming that there is no penalty for unchecked features (19b): if there is a phrase present that can check a feature, checking must take place. However, if there is no such phrase, a feature may unproblematically fail to be checked; the interfaces will still attempt to assign an interpretation and pronunciation to the resulting structure.

Lastly, following Chomsky (1995); Pesetsky & Torrego (2001); van Urk & Richards (2015), among others, I assume that the features  $[\cdot F \cdot]$  and  $[\cdot G \cdot]$  may be checked by either one or two Merge operations, depending on the features of the merged element. An element that only bears a feature F may only check  $[\cdot F \cdot]$ , and an element that only bears a feature G may only check  $[\cdot G \cdot]$ . As a result, if the numeration only supplies elements bearing either F or G but not both, checking the features  $[\cdot F \cdot]$  and  $[\cdot G \cdot]$  will require two separate instances of Merge. However, if an element is merged which bears both F and G, it may check  $[\cdot F \cdot]$  and  $[\cdot G \cdot]$  simultaneously. In fact, the condition in (19c) enforces multiple checking in such a case: merging an element bearing both F and G cannot have the result of selectively checking one Merge feature but not the other.

(19) Conditions on the satisfaction of Merge features:

- a. Merge features on a head are *unordered* (Longenbaugh 2019, contra e.g. Müller 2010).
- b. Obligatory Operations (Preminger, 2014; Longenbaugh, 2019): if checking can take

---

<sup>4</sup>It is worth noting that Longenbaugh (2019) makes a stronger claim, that we should give up on agreement as a precondition for movement entirely. He suggests that the the Agree operation which is normally thought to be a precondition for movement is really just a separate operation, which may co-occur with movement (or not), subject to other factors. Merge, on this view, is only constrained by conditions on feature-checking. If the present theory of the DOMA is correct, it provides additional support for this world view, by at least showing that we don’t *need* to distinguish Merge- and Move-inducing features. However, since the proposed treatment of the DOMA is still technically compatible with a view in which every feature that licenses movement first agrees with its goal, I will remain agnostic about this point.

place, it must take place. If checking cannot take place, features may unproblematically *fail* to be checked.

- c. Feature Maximality/Free Rider condition: Given a head H with features  $[F_1] \dots [F_n]$ , if XP discharges  $[F_i]$ , XP must also discharge each  $[F_j]$  that it is capable of (Chomsky, 1995; Pesetsky & Torrego, 2001; Rezac, 2013; van Urk & Richards, 2015; Longenbaugh, 2019)

- (20) Merging a bearer of F or G (but not both) checks one feature on H. Merging a bearer of *both* F and G checks both features on H.

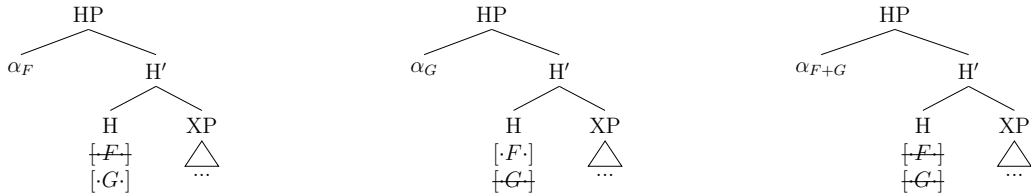

It is important to note that Feature Maximality is not a global economy condition. It does not tell a head what operation to do first. Whatever operation a head happens to choose at a given time, Feature Maximality merely requires it to maximize the number of features checked by the operand. Thus, the presence of an element bearing both F and G in the numeration does not necessarily bleed the possibility of merging an element bearing only F or G in Spec HP. However, its presence does impose limits on what orders of operations permit multiple specifiers. If the element bearing both F and G merges in Spec HP before anything else, it checks all of the features and blocks subsequent Merge steps which would create new specifiers. If an element bearing only F or G merges first, the remaining feature will license the element bearing both as a second specifier.

- (21) Different orders of operations yield different numbers of specifiers

- a. Merging  $\alpha_{F+G}$  before  $\alpha_F \rightarrow$  HP has one specifier

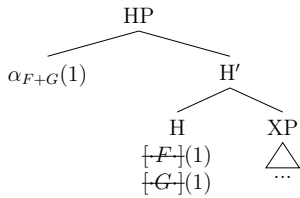

- b. Merging  $\alpha_F$  before  $\alpha_{F+G} \rightarrow$  HP has two specifiers

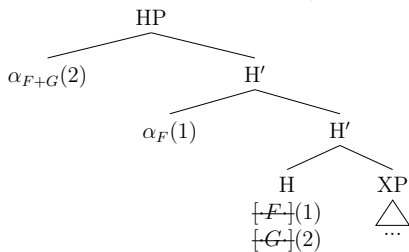

Until now, the illustration of these framework assumptions has made no mention of what kind of Merge brings about the specifiers in (21). The derivations in (21) are assumed to be available regardless of whether  $\alpha_{F+G}$  and  $\alpha_F$  are externally or internally merged in those positions. However, if Richards (1997) is right, internal Merge is subject to an economy condition

that doesn't apply to external Merge: *Shortest Move*. Shortest Move requires the landing site for movement to minimize the number of dominating nodes between it and its base position. In contexts with multiple specifiers, later moved specifiers must successively *tuck in* under previously merged specifiers, in order to create the closest possible Spec HP position to the base position.

Shortest Move therefore makes it so that the choice between internal and external Merge has consequences for the *order* of specifiers even if it doesn't affect the number of specifiers<sup>5</sup>. In a situation in which both  $\alpha_{F+G}$  and  $\alpha_F$  internally merge in Spec HP, adopting Richards (1997)'s *Shortest Move* predicts  $\alpha_{F+G}$  to tuck in under  $\alpha_F$ , resulting in a different order of specifiers, shown in (22). I will henceforth assume that movement tucks in, as in (22).

(22) Movement of  $\alpha_{F+G}$  that satisfies *Shortest Move* (Richards, 1997)

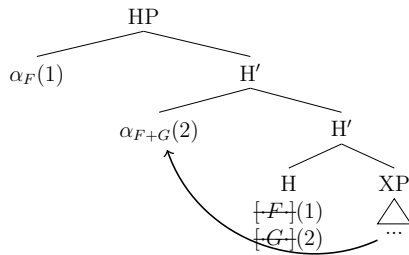

(23) Movement of  $\alpha_{F+G}$  that violates *Shortest Move* (Richards, 1997)

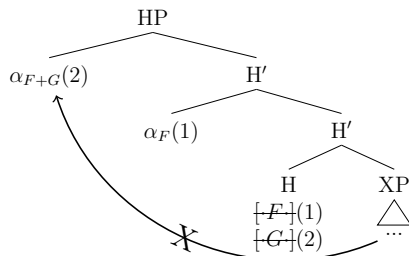

With these abstract properties of the framework in place, we are now in position to consider what structures are predicted given actual functional projections and their selectional features.

### 3.1.1 A note on locality and anti-locality

Any theory which uses the same features to license both internal and external Merge raises questions about how to formulate locality conditions on movement. I take up the standard assumption that feature-checking cannot involve just any constituent with the right features – the goal must also be in a domain that is local to the head controlling Merge, and it must not be c-commanded by any other potential goal for movement (Relativized Minimality).

<sup>5</sup>In principle, one could imagine a more general version of Shortest Move that would apply to external Merge. If the principle required Merge to minimize the distance between the licensing feature and merged element, all Merge would be expected to tuck in as in (22), thus recovering the unity of Merge in specifier ordering. Adopting this approach has no consequences for the present theory, however, so I leave it as a matter of speculation. It is also worth noting that Richards' formulation of Shortest Move was primarily discussed in contexts where multiple specifiers satisfied the *same* feature on H, whereas the present proposal generalizes it to contexts where each specifier might check a different feature as well.

I can imagine either of two views that capture Relativized Minimality effects in the present system. On one view, Merge features are universally endowed with a “probe”, which may search either the numeration/workspace or already built structure for a goal. If searching already built structure, this probe must search minimally (Chomsky, 2004) by stopping at the closest element with matching features that it finds. See Branan & Erlewine (2021) for an overview of some recent work on Minimal Search algorithms.

Alternatively, we might follow Longenbaugh (2019) in assuming that Merge features never have a “probe” – only agreement-inducing features probe – where a constraint like *Shortest Attract* (Richards, 1997) rules out some instances of feature-checking produced by movement. This representational constraint bans feature-checking by an element which is c-commanded by a comparable goal. For concreteness, I will adopt this representational view, described in the proxy rule in (24), because other aspects of the current framework are consistent with proposals in Richards (1997) and Longenbaugh (2019), though I do not believe anything hinges on this choice.

(24) Proxy locality principle:

In the configuration [ ... X<sub>[·Y·]</sub> ... YP<sub>1</sub> ... YP<sub>2</sub> ], where YP<sub>1</sub> c-commands YP<sub>2</sub>, YP<sub>2</sub> cannot check [·Y·] on X.

As indicated in §1, in cases with multiple specifiers, we need only the outermost one to be accessible to higher movement and agreement operations, which is captured by both of these approaches to locality.

Lastly, this theory treats feature-checking as a very local operation. In other words, a head with a feature [·F·] can only have its feature checked if a projection of that head merges with a bearer of F. It cannot check [·F·] by merging with something that itself does not bear F, but which dominates something that bears F<sup>6</sup>.

(25) Successful checking via sisterhood

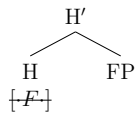

(26) No checking with a sister’s daughter

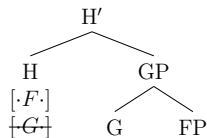

This system of feature-checking therefore contains an implicit Anti-locality constraint, like the one formulated by Abels (2003), and taken up in Holmberg et al. (2019). The FP in (25) is not accessible for movement to Spec HP, having checked the feature that allows (re-)merge with FP. The FP in (26), by contrast, is accessible for movement to Spec HP, since [·F·] was not checked by its sister.

---

<sup>6</sup>I therefore assume that when we see cases of pied-piping in wh-movement, it is because some mechanism allows wh-features to be projected on a larger constituent (see e.g. Heck 2008 or Cable 2010 for proposals along these lines), rather than because feature-checking can apply across intervening maximal projections (Chomsky, 1995).

Note that the relationship between checking and accessibility to movement is not sensitive to whether these checking operations form complements or specifiers. If H already had a complement, and were using features like  $[\cdot F \cdot]$  and  $[\cdot G \cdot]$  to form specifiers, the Anti-locality principle would make analogous predictions. The FP in (27) cannot remerge as a new specifier of HP, having already checked the feature that licenses Merge with HP. The FP in (28), by contrast, is accessible for movement to Spec HP, since there is a feature present to license such a movement step.

- (27) If a projection of H merges with FP,  $[\cdot F \cdot]$  gets checked.

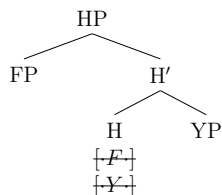

- (28) If a projection of H merges with something else,  $[\cdot F \cdot]$  does not get checked.

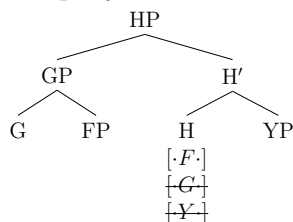

Of course, if movement from specifiers were banned for other reasons, such as the CED, then FP would not be allowed to move in (28). However, as smuggling derivations necessarily require movement from specifiers to be allowed in some cases, I will assume that movement of FP is permitted in (28), for reasons that will become clear when the smuggling derivations are introduced in §3.2.2. In fact, movement is required if permitted, according to Preminger (2014).

## 3.2 Feature-checking with actual functional projections

### 3.2.1 Subjects and wh-movement

In this section, we consider the kinds of Merge operations required to build  $v$ Ps and put these requirements in terms of Merge features to see how different Move and Merge operations are predicted to interact at the edge of  $v$ P. There are at least three general uses of Merge in building a  $v$ P: the kind that introduces arguments (e.g. the subject of the clause), the kind that builds the clause (e.g.  $v$  selects a VP complement), and the kind involved in successive cyclic wh-movement (Chomsky, 1986)<sup>7</sup>. According to the conjecture that all Merge is feature-driven, each of these uses of Merge must correspond to a feature on  $v$ , which predicts structures like (29) (i.e.

<sup>7</sup>Here I use the label  $v$  to describe the head that introduces the external argument, following the notation of Collins (2005); Merchant (2013). This notational choice is not strictly crucial to the theory – what is important is that there is a head which has these three functions: licensing a verbal complement, hosting the external argument, and hosting successive cyclic wh-movement through its edge. On a theory which treats  $v$  as a pure categorizing head, where Voice instead introduces the external argument, we could change the labels so that Voice instead has these features, and selects for a  $v$ P instead of a VP.

the canonical clause structure for transitive and intransitive clauses). Note that the presence of  $[\cdot wh\cdot]$  on  $v$  doesn't require every clause to be a wh-question, because features need only be checked in the presence of something that can check them. If no wh-expression is ever included in the numeration, the  $[\cdot wh\cdot]$  feature may simply fail to be checked with no consequences for grammaticality.

- (29)  $v$  must have at least three Merge features:  $[\cdot D\cdot]$ ,  $[\cdot V\cdot]$ ,  $[\cdot wh\cdot]$

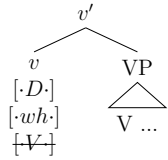

According to insights from Legate (2003), Sauerland (2003) and Longenbaugh (2019), the  $[\cdot D\cdot]$  feature on  $v$  has two potential functions: it may either introduce an external argument, as in a transitive/unergative clause, or it may license A-movement of an internal argument, as in a passive/unaccusative clause. In other words, the co-occurrence of both  $[\cdot D\cdot]$  and  $[\cdot wh\cdot]$  on  $v$  predicts both A- and  $\bar{A}$ -movement to be successive cyclic through  $vP$ .

Assuming that thematic roles are assigned by the head that interprets an argument (Kratzer, 1996; Pyllkänen, 2008; Ramchand, 2008; Harley, 2011, a.o.), both derivations in (30) are produced by the grammar, but the choice of  $v$  morpheme must be different depending on how its  $[\cdot D\cdot]$  feature is satisfied. An agentive  $v$  morpheme will be appropriate for specifiers formed by external Merge, which require a thematic role (30a). By contrast, a non-agentive  $v$  morpheme must be inserted when the specifier is formed by internal Merge, so the moving element does not receive two theta roles (30b). I assume that derivations which assign two theta roles to a single argument crash at the interfaces (*Theta criterion*, Chomsky 1981).

- (30)  $v$ 's requirement for a DP specifier represented as  $[\cdot D\cdot]$  in both transitive/intransitive contexts

a.  $[\cdot D\cdot]$  checked by external Merge

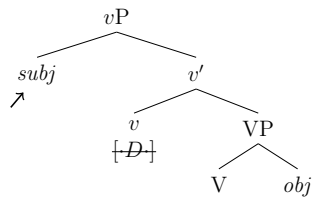

b.  $[\cdot D\cdot]$  checked by internal Merge

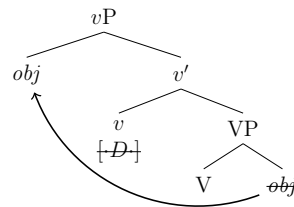

The co-occurrence of  $[\cdot D\cdot]$  and  $[\cdot wh\cdot]$  on  $v$  has implications for the time at which DPs that are also wh-phrases may Merge in Spec  $vP$ . Suppose a  $vP$  is being built, which contains an object wh-phrase. If the object wh-moves before a transitive subject is externally merged, it will check both  $[\cdot D\cdot]$  and  $[\cdot wh\cdot]$ , blocking an external argument from merging.

- (31) If a wh-object is internally merged first  $\rightarrow$  intransitive clause; subject can't Merge



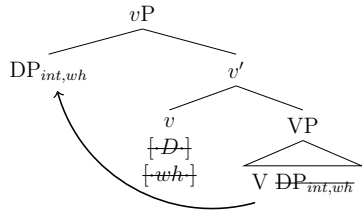

As a result, a transitive object wh-question *cannot* have the derivation in (31). The derivation in (31) must instead correspond to a passive/unaccusative clause, since there is no external argument, and the internal argument cannot be assigned multiple theta roles. A transitive object wh-question must therefore correspond to a derivation in which  $v$ 's  $[\cdot D \cdot]$  feature is satisfied by external Merge before its  $[\cdot wh \cdot]$  feature is satisfied by object movement. The tree in (32) reflects this order of operations, where the wh-object tucks in under the subject. A transitive object is therefore correctly predicted never to block the external argument from controlling subject agreement – if it merged as the first (i.e. outer) specifier of  $v$ , it would block the external argument  $DP_{int}$  from being introduced altogether. The external argument must therefore be the outer specifier, making it the highest accessible argument to a higher  $\varphi$ -probe.

- (32) Only possible derivation for a transitive object wh-question: 1) check  $[\cdot D \cdot]$  by merging subject, 2) check  $[\cdot wh \cdot]$  by moving object

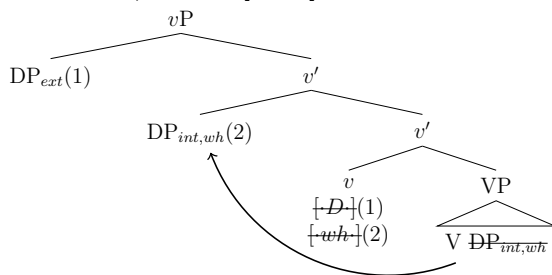

- (33) Some transitive vs. intransitive object wh-questions  
 a. Who arrived ~~wh~~? (corresponds to derivation (31))  
 b. Who did the cat cuddle ~~wh~~? (corresponds to derivation (32))

It might come as a surprise that the derivation in (32) is even allowed by the syntax, given that the derivation in (31) is more economical – it checks the same features in fewer operations. A strong global economy condition, like that found in van Urk & Richards (2015) (shown in (34)) would therefore rule out transitive object questions.

- (34) *Multitasking* (van Urk & Richards, 2015)

At every step in a derivation, if two operations A and B are possible, and the features checked by A are a superset of those checked by B, the grammar prefers A.

Since transitive object wh-questions clearly exist, I propose to weaken van Urk & Richards (2015)'s economy condition to that in (10), repeated below from §1. In this weaker form, economy can never enforce bleeding; it can only weakly pressure the derivation to check as

many features as early as it can. This weakened form of economy will make crucial predictions in contexts where no bleeding is at stake, as in wh-movement in passives<sup>8</sup>.

(10) *Weak economy*

At every step in a derivation, if two operations A and B are possible, and A checks more features than B, the grammar prefers A, *unless* doing B would check a subset of the features checked by A. In the latter case, the grammar optionally allows A or B.

Replacing A with “internally merge a wh-DP in Spec *v*P” and B with “externally merge a DP in Spec *v*P”, derivations (31) and (32) demonstrate that A checks a superset of the features that B does ( $[\cdot D \cdot] + [\cdot wh \cdot]$  vs. just  $[\cdot D \cdot]$ ). According to (34), (31) should therefore be the only possible derivation, which blocks transitivity. According to (10), however, either derivation should be possible; (10) only applies if there is no superset relationship between the two options, and one operation checks more features than the other.

§3.2.2 investigates the structure of ditransitive clauses, in preparation for the explanation of how A-movement and  $\bar{A}$ -movement in double object constructions interact, found in §4.

### 3.2.2 Ditransitives, passives, and smuggling

The previous section considered mono-transitive and intransitive clauses, in which *v* selects VP as a complement. In this section we review some structures commonly proposed for ditransitive clauses and see what features are required to describe them. There are two commonly discussed ditransitive constructions: the double object construction and the prepositional dative construction, shown in (35) and (36) for English and Norwegian.

(35) English ditransitives

- a. The cat gave Sue a mouse. (double object construction)
- b. The cat gave a mouse to Sue. (prepositional dative construction)

(36) Norwegian ditransitives (Anderssen et al., 2014, ex.2, p. 25)

- a. Jon ga Marit en bok.  
Jon gave Marit a book  
'Jon gave Marit a book.' (double object construction)
- b. Jon ga en bok til Marit.  
Jon gave a book to Marit  
'Jon gave a book to Marit.' (prepositional dative construction)

---

<sup>8</sup>One might worry that the condition in (10) requires the grammar to be able to “count” in a sense; it must be able to compare the cardinality of two feature sets, and identify the greater one. Given that the grammar is typically proposed not to be able to “count”, we might wonder whether this formulation of economy requires a significant enrichment to what the grammar can do. From what I can tell, however, the notion of counting that is needed in (10) is different than in the usual sense. Elsewhere in syntactic theory, the lack of counting in grammar is proposed to explain why there are no syntactic rules such as: *pronounce the verb in the fourth position in the clause* or *move the wh-element only to the second specifier position of head X*. In other words, the kind of counting that the grammar can’t do is enumerate elements in a string or structure and posit a rule that references particular number values in that sequence. The present notion of counting, however, does not refer to particular number values. Instead, it requires a comparison of the size of two feature sets, not unlike the kind of comparison needed to evaluate whether two feature sets stand in a subset relationship.

Double object constructions often lead authors to amend the  $vP$  structure proposed for transitive clauses by adding an additional functional projection which introduces a second internal argument (e.g. the VP-shells of Larson (1988), the prepositional shells of Harley (1995); Pesetsky (1995), or the applicative projections of (Marantz, 1993; McGinnis, 2001a; Pylkkänen, 2008, a.o.)). Holmberg et al. (2019) propose that the DOMA-exhibiting languages' double object constructions have the high applicative structure proposed by Pylkkänen (2008), shown in (37). The structure in (37) does not make VP  $v$ 's complement as in (29). Instead  $v$  selects for ApplP which selects for VP. By contrast, prepositional dative constructions are assumed to have the structure in (38), which preserves VP's status as  $v$ 's complement, and in which both internal arguments are dominated by VP.

(37) Pylkkänen (2008)'s high applicative structure for double object constructions

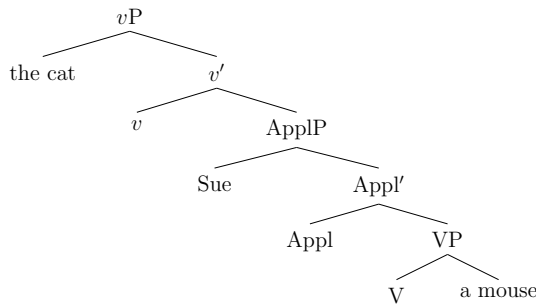

(38) Prepositional dative constructions

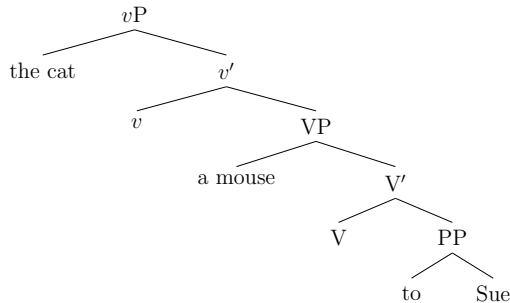

Prepositional dative constructions require no amendment to the list of features we assigned to  $v$ . Assuming, however, that Appl is not of category V (i.e. it is a derivational morpheme rather than a lexical verb), in order for the syntax to generate the double object structure in (37), we must update the list of features on  $v$  to include an extra feature, which licenses ApplP complementation (e.g. [ $\cdot$ Appl $\cdot$ ])<sup>9</sup>.

This amendment to the list of features on  $v$  is the direct result of two assumptions about Merge and the functional hierarchy: 1) that every instance of Merge must correspond to some licensing feature, and 2) that the functional hierarchy is a reflection of the distribution of category-selecting Merge features on heads. The functional hierarchy is specified such that  $v$  selects for VP in the absence of ApplP, but can alternatively select for ApplP, which selects

<sup>9</sup>I assume that the same  $v$  that licenses an external argument in a monotransitive clause is repurposed in ditransitive clauses, and thus still has the feature necessary to host a VP complement. A less restrictive theory would posit different feature bundles for  $v$  in each context (i.e. a  $v$  that selects for VP vs. a  $v$  that selects for ApplP), with no consequences for interpretation or pronunciation. I will not adopt this second possibility, since the conjecture that  $v$  has the same features in monotransitive and ditransitive clauses makes important predictions in the context of passivization, as we will see.

for VP (and no other order arises when those three elements are present). To account for this pattern,  $v$  must have features  $[\cdot V \cdot]$  and  $[\cdot Appl \cdot]$  and Appl must have  $[\cdot V \cdot]$ . In the absence of ApplP,  $v$  merges directly with VP and  $[\cdot Appl \cdot]$  goes unchecked. In the presence of ApplP,  $v$  selects for ApplP, which leaves  $[\cdot V \cdot]$  unchecked.

In sum, the proposed structures for prepositional datives and double object constructions have two notable syntactic differences: 1) the indirect object asymmetrically c-commands the direct object in (37), but the reverse is true in (38), and 2) the feature that normally licenses VP complementation goes unchecked in (37) but not in (38) (updated with Merge features in (39) and (40) respectively).

The asymmetric c-command relationship between the direct and indirect objects in each case would lead us to expect the following profile for passives of ditransitives: only the indirect object can be the passive subject in a double object construction, and only the direct object can be the passive subject in a prepositional dative construction. Attempting to raise the direct object in (39) or the indirect object in (40) should violate locality conditions on movement.

- (39) In a passive of a double object construction, the indirect object should always raise

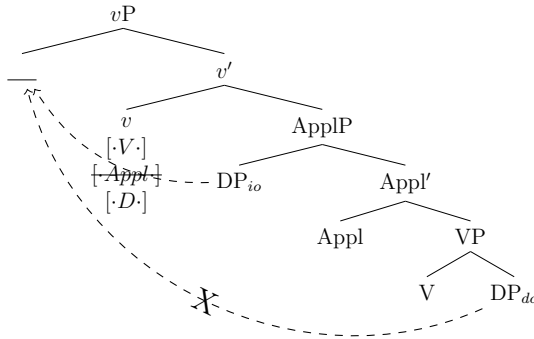

- (40) In a passive of a prepositional dative construction, the direct object should always raise

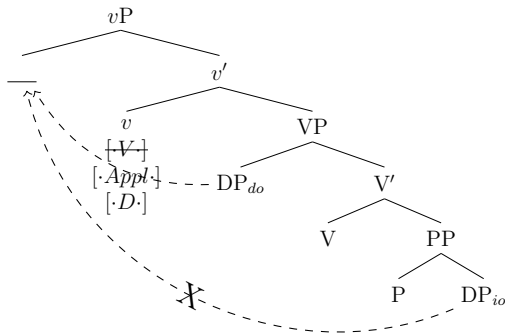

- (41) Predicted passives for each structure

- a. Sue was given a mouse. (cf. *\*A mouse was given Sue.*)
- b. A mouse was given to Sue. (cf. *\*Sue was given a mouse to.*)

While passives of prepositional dative constructions in Norwegian follow this prediction (42), passives of double object constructions do not. In (3), repeated below, we see that either object of a double object construction may raise to subject position in a passive, despite the fact that the proposed structure in (37) predicts (3a) to violate locality conditions.

- (42) *Norwegian asymmetric passives of prepositional datives* (Johannes Norheim, p.c.)
- a. En bok ble gitt \_ til Marit.  
a book was given to Marit  
'A book was given to Marit.'
  - b. \*Marit ble gitt en bok til \_.  
Marit was given a book to  
intended: 'Marit was given a book.'
- (3) *Norwegian symmetric passives of double object constructions* (Haddican & Holmberg, 2015, ex. 2, p. 146)
- a. Jeg ble gitt \_ Paralgin Forte.  
I was given Paralgin Forte  
'I was given Paralgin Forte.'
  - b. Lånet ble gitt meg \_.  
the.loan was given me  
'The loan was given to me.'

To resolve this issue, we could follow Holmberg et al. (2019) and take up a proposal from McGinnis (2001a,b) to allow the direct object to leapfrog past the indirect object to Spec ApplP. We could do this by adding features to Appl, which would attract the direct object to its edge and assign case to the indirect object, as they suggest. However, I propose that this solution is unnecessary – the features on *v* already provide the machinery we need to allow the direct object to raise, without leapfrogging.

I propose that the second difference between prepositional datives and double objects allows the direct object to raise: the unchecked [*V*] feature on *v* triggers movement of VP to Spec *v*P in a double object construction (shown in (43)), which breaks the *c*-command relationship between each object, licensing A-movement of the direct object without violating any locality conditions (shown in (44))<sup>10</sup>. Importantly, VP may move past the indirect object in (43) without violating any locality conditions because it is attracted by a different feature: VP is the closest *V*-bearing element to *v*, and DP<sub>*io*</sub> is the closest *D*-bearing element to *v*. This is essentially a *smuggling* approach to double object constructions, similar in spirit to the analysis proposed by Collins (2005) for passives in general. Symmetric passives are therefore entailed by the double object structure in (37), due to the unchecked [*V*] feature<sup>11</sup>.

- (43) VP-movement licensed by [*V*] *smuggles* the direct object past the indirect object

<sup>10</sup>In order for A-movement out of the raised VP to be possible, the CED must not be active in this context, or alternatively, freezing must not take place when VP moves to Spec *v*P. While I do not take a stand on whether the CED or freezing should be abandoned in general, note that Müller (2010)'s account of them predicts CED/freezing to be obviated in exactly this context. According to his approach, only last-merged specifiers are barriers for extraction. In this context, VP moves to Spec *v*P before the last feature on *v* is checked. Since it isn't the last-merged specifier, Müller's account predicts subextraction of a DP to be allowed.

<sup>11</sup>See §A.2 for additional thoughts on how the feature-checking logic constrains our representations of the functional hierarchy.

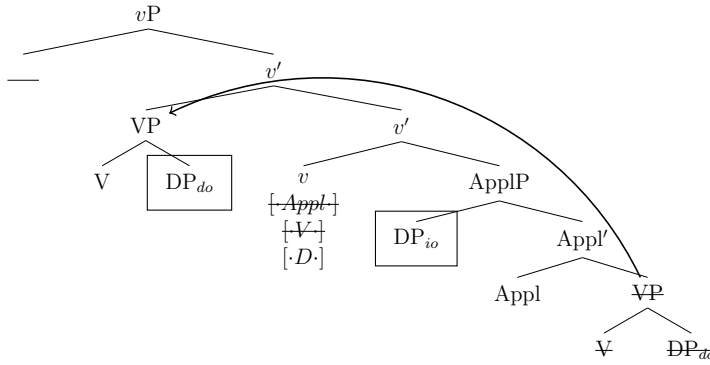

- (44) Neither argument c-commands the other, so either may move to Spec  $vP$  without violating locality conditions

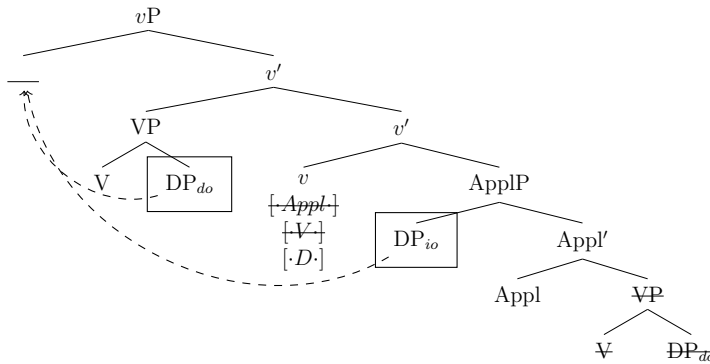

The present analysis shares with Collins (2005) the proposal that the direct object can be moved past another argument if its dominating phrase moves first. However, the implementation of this proposal differs from Collins (2005) in several respects. In particular, an unchecked  $[-V]$  feature on  $v$  is required to license smuggling on the present approach, which occurs in double object constructions but not in monotransitive clauses. Collins proposes that smuggling always occurs in passives, even in monotransitives, contra the present account. I also do not adopt Collins' proposal to treat the implicit agent in a passive as a DP in Spec  $vP$ , or else it would block raising of an internal argument. I therefore assume that the implicit agent in passives is not represented in the syntax (Bruening, 2013; Legate, 2014; Schäfer & Pitteroff, 2017, a.o.)<sup>12</sup>.

In sum, each ditransitive structure in languages like Norwegian allows a different set of elements to become the subject of a passive. The prepositional dative construction only permits the direct object to be the subject of a passive, because it asymmetrically c-commands the indirect object, and no features independently proposed on  $v$  license smuggling of the indirect object past the direct object<sup>13</sup>. The double object construction permits either object to raise

<sup>12</sup>Because of the differences between the present approach and that of Collins (2005), the present treatment of smuggling in passives does not suffer from the criticism of smuggling presented in Bowers (2010); Legate (2014), which focus on monotransitives and the status of the implicit agent.

<sup>13</sup>It is worth noting that Mills (2008) discusses a phenomenon in some English varieties in which prepositional dative constructions appear to permit raising of the indirect object past the direct object, as in e.g. *%Mary was written a letter to* (Mills, 2008, p.14, ex. 6). Mills argues, based on semantic and syntactic restrictions on the direct object in such cases, that the direct object is actually not a DP here, but rather has a reduced status which licenses pseudo-passivization across it. A reviewer notes that according to Engdahl & Laanemets (2015), Norwegian has this as well if the direct object is part of an idiom.

to subject position in a passive, because the double object construction leaves [ $\cdot V \cdot$ ] unchecked, which licenses smuggling of the direct object past the indirect object<sup>14</sup>.

When *wh*-movement is added to the mix, observe that only double object constructions reject the combination IO-*wh*-movement+DO-passive; prepositional dative constructions permit the direct object to be the subject of a passive in (45). Thus, empirically, we find that only contexts in which the indirect object could in principle be the passive subject show the bleeding effect of the DOMA.

- (4) **“Double object movement asymmetry”** (DOMA): the direct object cannot be the subject of a passive in which the indirect object has *wh*-moved (subjects in bold) (Holmberg et al., 2019, ex. 5d,a, p.680)

- a. \*Hvem ble **boka** gitt \_ \_?  
 who was the.book given  
 intended: ‘To whom was the book given?’ *DO=subject; IO=wh-phrase*
- b. **Hvem** ble gitt \_ boka?  
 who was given the.book  
 ‘Who was given the book?’ *IO=subject; IO=wh-phrase*

- (45) *Norwegian* passive+*wh*-movement in prepositional datives (Johannes Norheim, p.c.)

- a. Til hvem ble **boka** gitt?  
 to who was book.the given  
 ‘To whom was the book given?’
- b. Hvem ble **boka** gitt til?  
 who was book.the given to  
 ‘Who was the book given to?’

§4 will explain this effect by appealing to the following asymmetry between the direct and indirect object of a double object construction: indirect object movement in a passive can proceed straight from its base position, while direct object movement is contingent on VP-movement.

In sum, we have seen that the logic of feature-checking, combined with the double object structure in (37), predicts that direct objects should be smuggled past indirect objects in a double object construction. As such, both internal arguments of a double object construction are available for A-movement in a passive, since neither c-commands the other. In §4, we see how the timing of VP-movement relative to *wh*-movement predicts the DOMA.

Before moving on, I want to briefly address the implications of smuggling for verb position and pronunciation. A reviewer notes that in many of the languages under discussion, the verb surfaces in a position higher than *vP*, such as T or C. As such, verb movement to a higher position must be possible, despite the fact that VP has moved to a specifier position. According to Baker (1988), at least some kinds of head movement are not permitted to escape specifiers, which makes the co-existence of smuggling and V-to-T/C movement surprising.

That said, Harizanov & Griбанова (2019) argue that some kinds of head movement, most notably V-to-T/C movement in some languages, shows properties of phrasal movement. For

<sup>14</sup>Though this paper focuses primarily on passive contexts, see Newman (2021) for arguments that VP-specifier-hood in double object constructions occurs more generally, which is predicted by the present distribution of features.

example, head movement in several Scandinavian languages (among others, e.g. Bulgarian) appears to violate the head movement constraint: there is evidence that the verb moves to C, but no evidence that it moves through lower aspect and tense heads along the way. They therefore conclude that what we call *head movement* is not a homogenous phenomenon. Some types of head movement are derived by genuine movement in the syntax to a specifier position, which can skip intermediate head positions, followed by a morphological process which fuses it to the nearest head complex (Matushansky, 2006). Other types of head movement, by contrast, are derived in the post-syntax, by morphological processes that proceed in a “roll-up” fashion, where each head is sequentially affixed to the verbal complex, and no heads can be skipped. Whether Baker’s constraint applies to both kinds of head movement, vs. just the latter kind, is an open question.

For the present analysis, smuggling demands that phrasal movement be allowed to escape a VP specifier. As such, we would expect head movement with phrasal properties to be able to escape a VP specifier as well. Harizanov & Gribanova (2019) discuss Norwegian as being one of the languages with head movement constraint-violating movement, in which case we expect smuggling to be able to feed head movement out of VP in Norwegian just as it feeds movement of a direct object from VP<sup>15</sup>.

## 4 Explaining the DOMA

§3 established a logic of feature-checking that predicted a smuggling derivation for double object constructions – VP raises to Spec *v*P, which brings the direct object to a position not c-commanded by the indirect object. The lack of c-command between internal arguments predicts symmetric passives, since either argument can A-move without violating locality conditions. In this section, we consider how the [*wh*] feature on *v* is expected to affect the possible derivations of passives of double object structures where different arguments are wh-phrases, and show that the DOMA is predicted as long as the order of operations is constrained by the economy principle in (10).

(10) *Weak economy*

At every step in a derivation, if two operations A and B are possible, and A checks more features than B, the grammar prefers A, *unless* doing B would check a subset of the features checked by A. In the latter case, the grammar optionally allows A or B.

To see how the economy condition in (10) predicts the DOMA, we need to build a passive *v*P of a double object construction step by step, and see how the derivations are affected by making different arguments wh-phrases. Let’s begin by making the direct object a wh-phrase. Starting with a *v* head that has features [*D*·], [*wh*·], [*V*·], and [*Appl*·], *v* must begin by merging ApplP as a complement. ApplP checks the [*Appl*·] feature on *v*, which leaves [*D*·], [*wh*·], and [*V*·] for licensing VP movement and movement of an argument to Spec *v*P.

(46) Step 1: Merge(*v*,ApplP)

---

<sup>15</sup>For more on head movement in this framework, see §A.3.



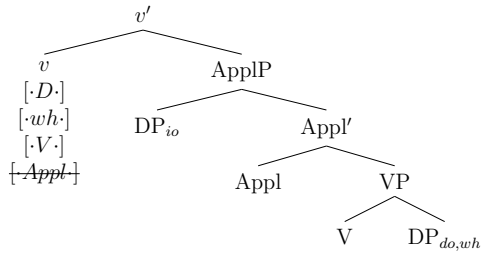

At this point in the derivation, there are two operations that might target the edge of  $vP$  without violating locality conditions: A-movement of the indirect object, or VP-movement (i.e. *smuggling*)<sup>16</sup>. Since both operations check just one feature, Weak Economy does not decide between them, and so two derivational paths are possible from the starting point in (46).

If the indirect object raises first (47a), the remaining features license VP-movement (which tucks in due to Shortest Move) and  $wh$ -movement of the direct object (which also tucks in under  $DP_{io}$ ), shown in (47b)<sup>17</sup>. The resulting structure is one in which the indirect object is the highest accessible argument to further A-movement/agreement. Moreover, nothing about this configuration is proposed to block  $wh$ -movement of the direct object, and so the result is a direct object question of an indirect object passive.

(47) Option 1: Check  $[\cdot D \cdot]$  with  $DP_{io}$  before checking  $[\cdot V \cdot]$  with VP

a. Step 2: Move  $DP_{io}$

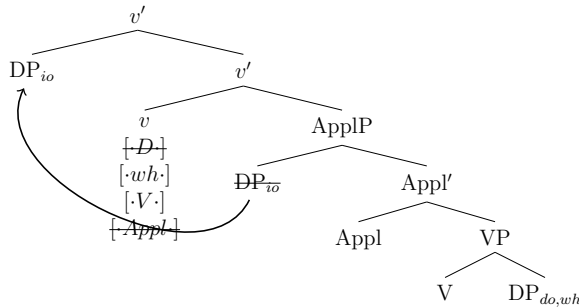

b. Continuation of (47a): Move VP (tucks in) then move  $DP_{do,wh}$  (tucks in)

<sup>16</sup>I assume conservatively that  $wh$ -movement of the direct object at this stage would violate locality conditions because it would jointly check  $[\cdot D \cdot]$  and  $[\cdot wh \cdot]$ . If checking  $[\cdot D \cdot]$  as a non-local DP is ruled out, the direct object cannot be considered for feature-checking at this point. See also Coon et al. (2021) and Branan & Erlewine (2022), and references there, for discussion about intervention effects in such contexts, with a theory of probing in movement.

<sup>17</sup>Shortest Move actually doesn't decide whether the direct object moves to a position that c-commands VP, as shown, or to a lower specifier position, closer to  $v$ . Since the choice doesn't matter for our purposes, I will assume that it moves to the closest position that c-commands its base position.

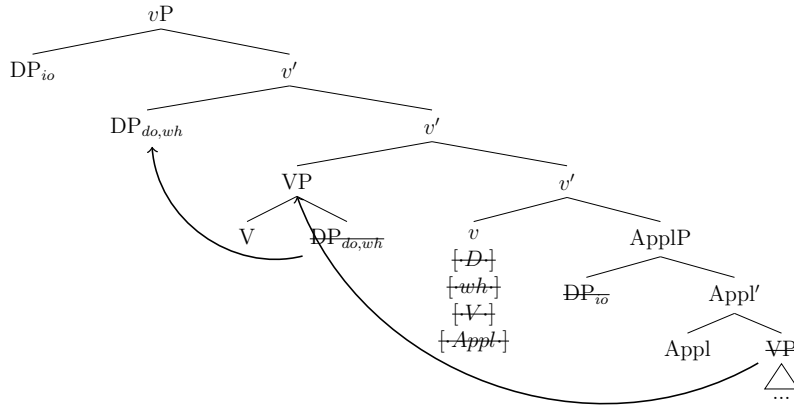

If VP moves first instead, two derivational options are available, both of which make the direct object the highest accessible argument. After  $[\cdot V \cdot]$  is checked, only features  $[-D \cdot]$  and  $[-wh \cdot]$  remain. Since the two elements that can check these features stand in a subset relationship, Weak Economy does not decide whether the direct object wh-moves first and checks both features, or if the indirect object raises before the direct object wh-moves. Whether the indirect object moves first is irrelevant, however, because the indirect object must tuck in below VP if it moves, and thus below the direct object. I have therefore left it in situ in (48b) to make the derivation clearer.

(48) Option 2: check  $[\cdot V \cdot]$  with VP before checking  $[-D \cdot]$

a. Step 2: Move VP

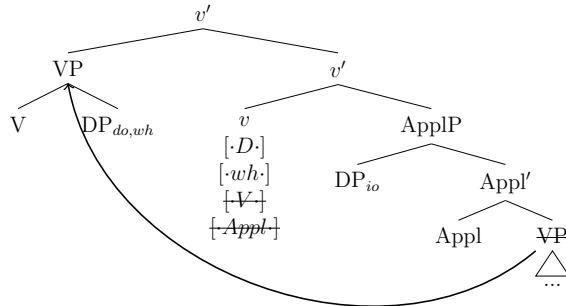

b. Continuation of (48a): Move  $DP_{do,wh}$

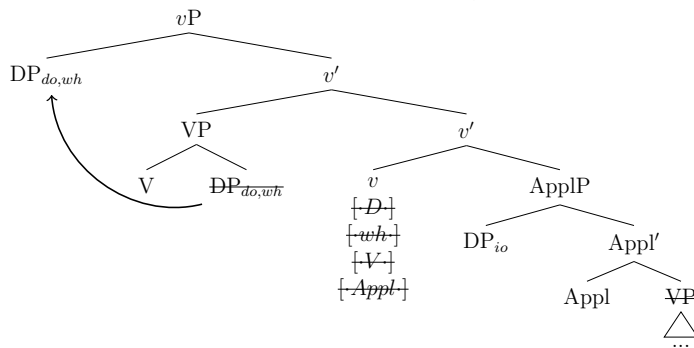

In sum, a passive of a double object construction, in which the direct object is a wh-phrase, is compatible with two possible outcomes. Either the indirect object raises before VP, and ends

up as the outermost specifier of  $vP$  due to tucking in, or  $VP$  is moved first, which allows the direct object  $wh$ -phrase to raise to become the highest accessible  $DP$ . Assuming that the highest  $DP$  in  $vP$  is the one that controls subject agreement/raises to subject position, the outcome in (47b) feeds an indirect object passive (pronounced as (50)), while the outcome in (48b) feeds a direct object passive (pronounced as (51))<sup>18</sup>.

(49) T attracts/agrees with highest accessible DP

a. Continuation of (47b):  $DP_{io}$  is the subject of the clause

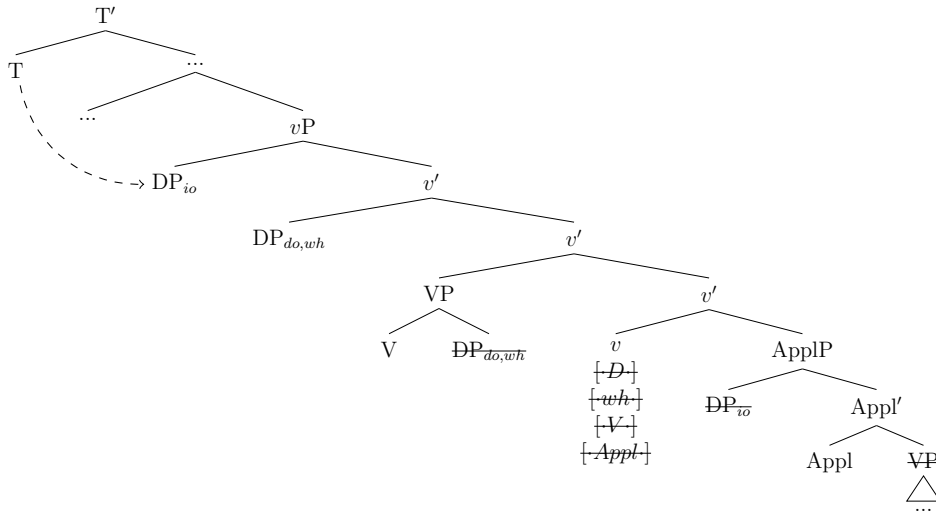

b. Continuation of (48b):  $DP_{do,wh}$  is the subject of the clause

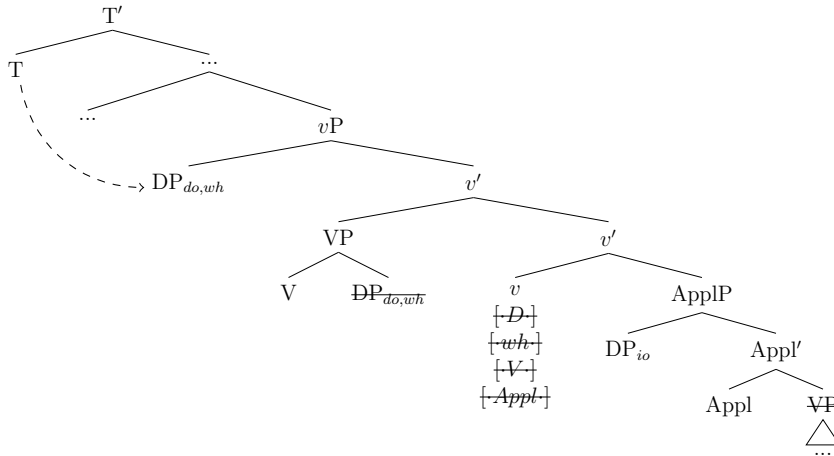

(50) Checking  $[\cdot D \cdot]$  before  $[\cdot V \cdot]$   $\rightarrow$  indirect object passive

a. Hvilken bok ble Jon gitt?

which book was Jon given

‘Which book was John given?’

*DO wh-movement from IO passive*

(51) Checking  $[\cdot V \cdot]$  before  $[\cdot D \cdot]$   $\rightarrow$  direct object passive

a. Hvilken bok ble gitt Jon?

which book was given Jon

<sup>18</sup>See §A.1 for an explanation of why the  $wh$ -object in (49b) can raise to subject position without violating the ban on improper movement.

Repeating the exercise with a wh-moving *indirect* object yields a different result. In this case, early movement of the indirect object in Step 2 is enforced by Weak Economy. In Step 2, moving the wh-indirect object now checks both  $[\cdot D \cdot]$  and  $[\cdot wh \cdot]$ , whereas moving VP would only check  $[\cdot V \cdot]$ . The indirect object therefore checks more features, and moving VP does not check a subset of those features, so only Step 2a is allowed by Weak Economy.

(52) Step 1: Merge( $v$ , ApplP)

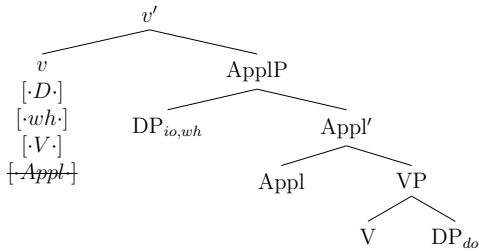

(53) Step 2: check **both**  $[\cdot D \cdot]$  and  $[\cdot wh \cdot]$  with  $DP_{io,wh}$  vs. check **only**  $[\cdot V \cdot]$  by merging a VP

a. Option 1: Move  $DP_{io,wh}$  first (enforced)

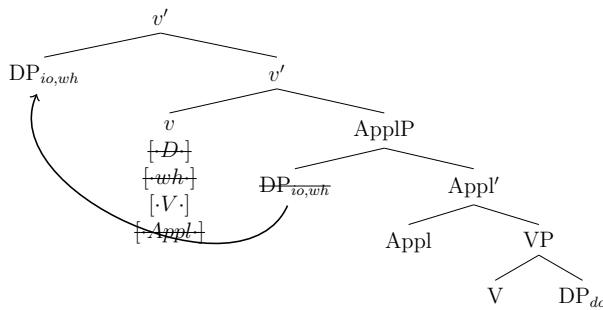

b. Option 2: Move VP first (blocked)

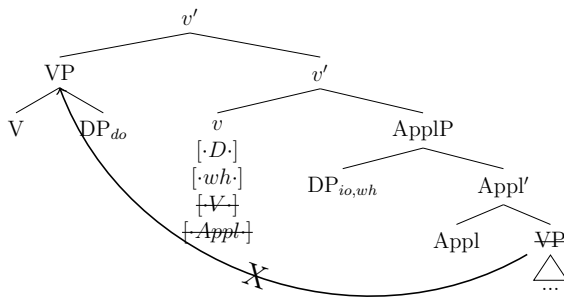

Because the indirect object moves to Spec  $vP$  before VP is merged, the indirect object becomes the outermost specifier of  $vP$  – every subsequent specifier of  $vP$  tucks in under it, making the indirect object the highest accessible argument for subject agreement/A-movement. As a result, only (54), pronounced in (55), is derived.

(54) Only derivation available when the indirect object is a wh-phrase

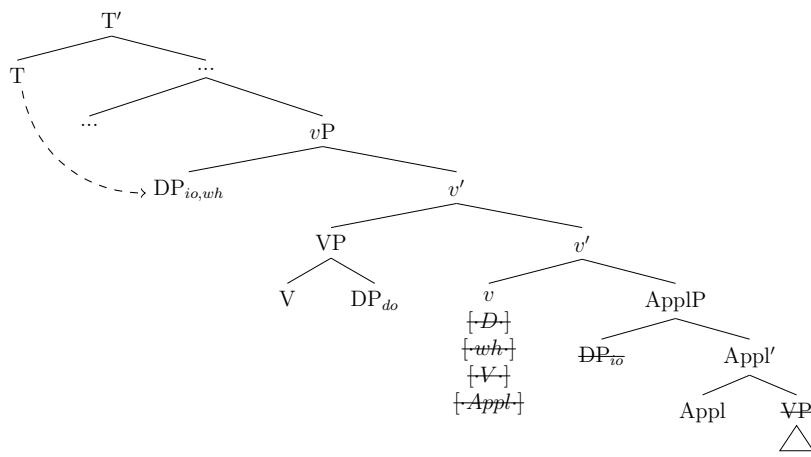

(55) Checking [ $\cdot D \cdot$ ] and [ $\cdot wh \cdot$ ] before [ $\cdot V \cdot$ ]  $\rightarrow$  indirect object passive

a. Hvem ble gitt boka?

who was given the.book

‘Who was given the book?’

*IO wh-movement from IO passive*

(56) Checking [ $\cdot V \cdot$ ] before [ $\cdot D \cdot$ ] not an option  $\rightarrow$  no direct object passive

a. \*Hvem ble boka gitt?

who was the.book given

intended: ‘To whom was the book given?’

*IO wh-movement from DO passive*

(Norwegian; Holmberg et al. 2019, ex. 5d, p.680)

This account of the DOMA rests on the following assumption about what makes an element a suitable subject: it must be accessible to the probe/attractor responsible for subject agreement/position. In (54), the direct object cannot be the subject of the clause because it is c-commanded by the indirect object, which is accessible to agreement/A-movement. Attempting to pronounce the direct object in subject position, as in (56), is therefore blocked.

This account therefore makes an important prediction: if the indirect object were not a DP, and therefore could not move to Spec  $vP$ , or if it were a DP that was inaccessible to a higher probe for some reason, the direct object *could* end up being the closest accessible goal to a higher probe. In such a case, the DOMA should not arise –  $wh$ -indirect objects can’t block a direct object passive if they can’t be passive subjects themselves. Greek is such a language whose indirect objects never control subject agreement, and which also does not exhibit the DOMA.

(57) Greek doesn’t have indirect object passives or the DOMA restriction

a. \*I Maria stalthike to grama.

the Maria.NOM sent.N-ACT.3SG the letter.ACC

intended: ‘Mary was sent the letter.’ (Anagnostopoulou, 2003, ex. 10a, p. 11)

b. Tinos dhothike to vivlio?

who.GEN gave.N-ACT.3SG the book.NOM

‘Who was the book given to?’ (Anagnostopoulou, 2003, ex.308, p. 221)

On the present approach, Greek must therefore differ from Norwegian in either of two ways: 1) by never permitting indirect objects to check a [ $\cdot D \cdot$ ] feature, or 2) by making indirect

objects inaccessible to subject agreement. These abstract differences follow naturally from an observable difference between Norwegian and Greek indirect objects. In Norwegian, indirect objects of double object constructions have no overt inherent case, while Greek indirect objects in the same context are marked with genitive. Assuming with Lamontagne & Travis (1987), Bittner & Hale (1996), Neeleman & Weerman (1999), Rezac (2008), Caha (2009), Pesetsky (2013), Levin (2015), among others, that inherent case may be realized as a prepositional shell around a nominal, the difference between Norwegian and Greek can be reduced to the syntactic category of its indirect objects: Norwegian indirect objects are represented as DPs while Greek indirect objects are represented as PPs. This choice both affects the features that each argument can check, as well as their accessibility to  $\varphi$ -Agreement<sup>19</sup>.

To briefly elaborate on my assumptions about case: I assume that some languages' indirect objects have inherent case due to an idiosyncratic property of their applicative morphemes: some applicative morphemes l-select for a PP, or license inherent case on their arguments, while others do not. Arguments that do not receive inherent case get assigned structural case, which I assume is computed based on whichever argument raises to subject position in the language (either via licensing by T or via a dependent case mechanism).

Sections 4.1 and 4.2 examine some languages which do and do not exhibit the DOMA, and motivate the present analysis of them. Before moving on, however, I want to clarify why wh-indirect objects only block *direct objects* from subject position, but not transitive subjects. Norwegian, for example, permits indirect objects to wh-move in active transitive clauses, suggesting that indirect objects are capable of wh-moving without checking [ $\cdot D$ ].

(58) Hvem ga du boka?  
 who gave you the.book

‘Who did you give the book to?’ (Holmberg et al., 2019, ex. 3a, p.678)

The difference between externally merging a transitive subject and internally merging a direct object is that external Merge need not be preceded by VP-movement while internal Merge of a direct object is contingent on VP-movement. As a result, the stage at which a wh-indirect object is considered for wh-movement is a stage at which an alternative operation is available involving the transitive subject, namely *externally Merge the subject*. Externally merging a subject checks a proper subset of the features that would be checked by wh-moving the indirect object, and so Weak Economy does not decide between them: the transitive subject may merge first to avoid being bled.

---

<sup>19</sup>Technically, the choice of whether to represent inherent case as a preposition vs. DP-morphology makes slightly different predictions about the derivational history of wh-indirect objects. Wh-indirect objects that are PPs should never raise to subject position or control agreement, but wh-indirect objects that are opaque DPs could raise to subject position without controlling agreement. It is possible that languages whose direct objects may control subject agreement in situ are of the latter sort: their indirect objects may move to subject position without controlling agreement, which blocks the direct object from raising but not from controlling agreement. A reviewer points out that Dutch (den Besten 1985), German (Haider 1992, Wurmbrand 2005), and Greek (Alexiadou & Anagnostopoulou 1998) allow subject agreement with in situ objects, which advocates either treating their indirect objects like opaque DPs rather than PPs, or suggests that these languages lack a relevant EPP property for subjects altogether, making the category distinction irrelevant. Since this paper is primarily about predicting the distribution of DOMA effects cross-linguistically, and not about the source of inherent case, I leave exploration of these two options to future research. For the present, it is mainly important that indirect objects in these languages don't block direct objects from acting like the surface subject with respect to the morphosyntactic alignment of the clause (i.e. it doesn't prevent them from looking nominative or controlling subject agreement).

(59) Step 2: two options! Check [ $\cdot D$ ] and [ $\cdot wh$ ] with  $DP_{io,wh}$  or check [ $\cdot D$ ] with  $DP_{ext}$

a. Option 1: Move  $DP_{io}$  first

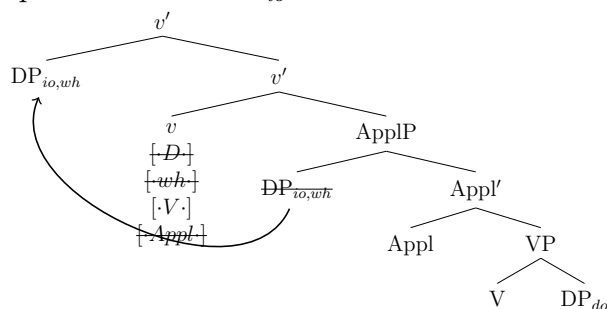

b. Option 2: Merge  $DP_{ext}$  first

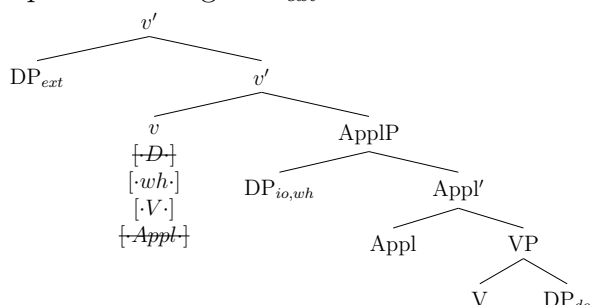

When the rest of the clause is built, Option 1 makes the indirect object the only accessible argument for raising to subject. Furthermore, there is no external argument, meaning that this structure can only be realized as an indirect object passive (60a). Option 2 makes the external argument the highest accessible argument for raising to subject, resulting in a transitive clause (60b).

(60) Options 1 and 2 realized in Norwegian

a. Hvem ble gitt boka?

who was given the.book

‘Who was given the book?’ (Holmberg et al., 2019, ex. 5a, p. 680)

b. Hvem ga du boka?

who gave you the.book

‘Who did you give the book to?’ (Holmberg et al., 2019, ex. 3a, p. 678)

In sum, since Weak Economy never enforces bleeding derivations, which is why transitive object *wh*-questions are permitted more generally, there is always a derivation available in which the transitive subject is merged before the indirect object *wh*-moves. The same cannot be said for the direct object, however, which must be smuggled by VP before it can A-move – VP-movement cannot be bled by indirect object movement and is thus subject to Weak Economy. Sections 4.1 and 4.2 show that this account extends beyond Norwegian and Greek to several other languages with symmetric and asymmetric passives respectively.

## 4.1 Languages with symmetric passives

Holmberg et al. (2019) report that the DOMA is observed in the following languages: Norwegian, North-West British English, Zulu, Lubukusu, Xhosa (Visser, 1986), Swati (Woolford,

1995), Haya (Duranti & Byarushengo, 1977), Fuliiru (Van Otterloo, 2011), Sotho (Morolong & Hyman, 1977), and Tswana (Creissels, 2002). All of these languages have in common that their double object constructions permit symmetric passivization: either direct or indirect object may in principle be the subject of a passive. Note that Holmberg et al. report the DOMA in multiple  $\bar{A}$ -movement contexts, not just wh-movement. Relativization also shows the DOMA, as seen in the Zulu relative clauses in (61)<sup>20</sup>. This is unsurprising if all  $\bar{A}$ -phenomena are controlled by an  $\bar{A}$ -feature on heads like *v* and C.

- (61) *Zulu*: relativization+passive (Holmberg et al., 2019, ex. 14a,15a, p. 683, citing Zeller 2011)
- a. I-nyama u-mama a-yi-phek-el-w-a-yo i-mnandi.  
 9-meat 1a-mother REL.1SM-9OM-cook-APPL-PASS-FV-RS 9SM-tasty  
 ‘The meat that Mother is being cooked is tasty.’ *IO=subject; DO=wh-phrase*
- b. \*U-mama i-nyama e-m-phek-el-w-a-yo u-kathele.  
 1a-mother 9-meat REL.9SM-1OM-cook-APPL-PASS-FV-RS 1SM-tired.  
 intended: ‘Mother, for whom the meat is being cooked is tired.’ *DO=subject; IO=wh-phrase*

Also important to note is that overt  $\bar{A}$ -movement data exhibiting the DOMA are only available in some of these languages. Nonetheless, Holmberg et al. (2019) suggest that many of these languages have another situation in which the DOMA is visible, namely in the distribution of object marking on the verb more generally. In the Zulu DOMA examples in (61), notice that there is a morpheme glossed OM on the verb, which is proposed to be a kind of agreement that may cross-reference non-oblique objects (but not oblique ones, see Halpert 2012 p. 223-224 for discussion).

The status of this object marking is subject to some debate (see van der Wal 2015 for an overview). What is unique about it is that it never cross-references in situ or A-moved objects – passive subjects never control object agreement. Rather, the object agreement is partly discourse driven in that it tracks arguments that either  $\bar{A}$ -move or right-dislocate from their in situ positions within *vP* to a *vP*-external position (or drop altogether). This movement/agreement correlation is shown in (62), where we observe that the verb agrees with whichever object has right-dislocated (and may be dropped). If neither one moves, there is no agreement. Following Iorio (2014) and van der Wal (2015), I will assume that there is a  $\varphi$ -probe controlling this agreement on *v*, but that it is more selective than many  $\varphi$ -probes – it only targets arguments with certain information structural properties<sup>21</sup>. Hence, in (61), the relativized argument is shown to control object agreement on the verb.

- (62) *Zulu*: flexible object agreement
- a. U-John u-nik-a aba-ntwana i-mali.  
 1a-John 1SM-give-FV 2-children 9-money

<sup>20</sup>(Holmberg et al., 2019, ex.6) also provide relativization data in Norwegian, which also show the DOMA.

<sup>21</sup>Scott (ms) discusses a typology of “composite” probing (van Urk, 2015) that is well-suited to capture this kind of discourse sensitivity in  $\varphi$ -agreement. On a composite-probing approach, the  $\varphi$ -probe in Zulu has a component which targets  $\bar{A}$ -features as well as  $\varphi$ -features, and does not interact with elements that bear one but not the other feature. Probing of a similar sort is also sometimes used in the Austronesian literature to explain certain interactions between wh-movement and Voice. See especially Branan & Erlewine (2022) for a recent overview, which builds on ideas from Aldridge (2004, 2008), among others.



‘John is giving the children money.’ (Zeller, 2012, ex. 9a, p. 222)

- b. U-John u-**ba**-nik-a i-mali (aba-ntwana).  
 1a-John 1SM-2OM-give-FV 9-money 2-children

‘John is giving them money (the children).’ (Zeller, 2012, ex. 9c, p. 222)

- c. U-John u-**yi**-nik-a aba-ntwana (i-mali).  
 1a-John 1SM-9OM-give-FV 2-children 9-money

‘John is giving it to the children (the money).’ (Holmberg et al., 2019, ex. 25c, p. 688, citing Zeller 2011)

- (63) A  $\varphi$ -probe on  $v$  agrees with arguments with certain discourse properties

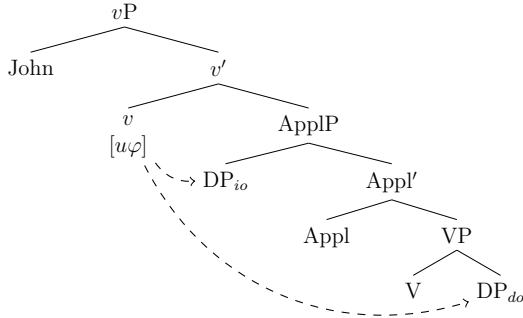

If this analysis of object marking is correct, we would expect to see the DOMA restriction in any context where the recipient controls object marking, not only if it is the target of relativization or overt left dislocation – the theory predicts that if the indirect object is available for any additional operation at  $v$ , not just  $wh$ -movement, it is predicted to move early and give rise to DOMA-like effects, as illustrated in (64) and (65).

- (64) Step 1: Merge( $v$ , ApplP)

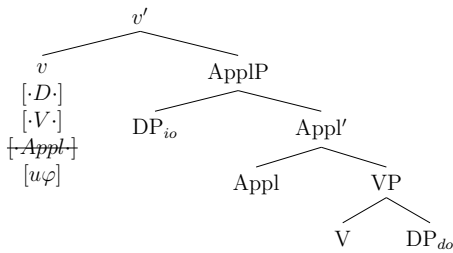

- (65) Step 2: if the IO has the right discourse properties to value  $[u\varphi]$ , it can check/value **both**  $[\cdot D\cdot]$  and  $[u\varphi]$ ; merging VP **only** checks  $[\cdot V\cdot]$  → Weak Economy enforces IO raising+agreement

- a. Option 1: Move  $DP_{io}$  first (enforced)

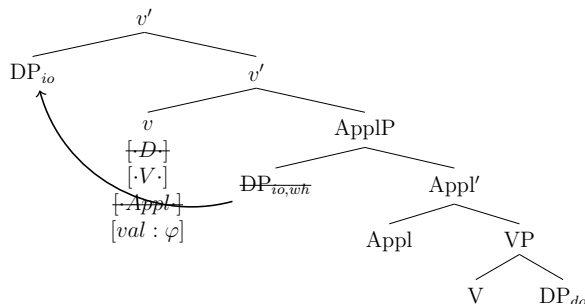

b. Option 2: Move VP first (blocked)

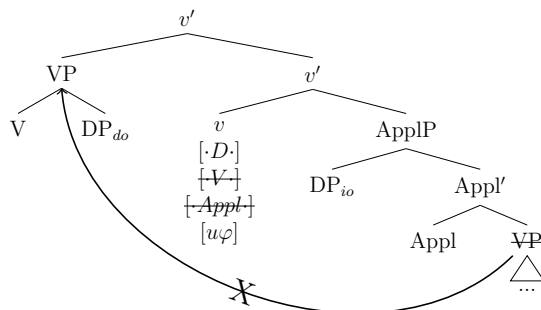

This is indeed what Holmberg et al. (2019) propose that we find in all of the Bantu languages in their sample, illustrated in (66-67) for Xhosa and Swati: recipient passives permit the direct object to control object agreement, but theme passives do not permit the recipient to control object agreement. If the recipient is available for object agreement in (66/67b), it has to simultaneously value  $[u\phi]$  and check  $[\cdot D\cdot]$  before smuggling can take place, which blocks the theme passive. The glossing conventions in (66) and (67) reflect those adopted by the cited authors: the referent of object marking in (66) is shown by co-indexation; the referent of object marking in (67) has been dropped, but the phonological forms of the agreement markers in both examples are transparent (*(w)u* when the controller of agreement is *banana* and *si* when it is *friend*).

(66) *Xhosa* (Visser, 1986, ex.16, p. 132)

- a. Umfundi u-ya-yi-nik-w-a incwadi.  
 student SAGR-PRES-OM<sub>i</sub>-give-PASS-PRES book<sub>i</sub>  
 ‘The student was given a book.’
- b. \*Incwadi i-ya-m-nik-w-a umfundi.  
 book SAGR-PRES-OM<sub>i</sub>-give-PASS-PRES student<sub>i</sub>  
 intended: ‘A book was given to the student.’

(67) *SiSwati* (De Guzman, 1987, ex. 1f,e, p. 314)

- a. Sínínì sí-wù-ník-w-è ngù Jóhn.  
 friend SAGR-OM-give-PASS-TNS by John  
 ‘The friend was given it by John.’
- b. \*Bànánà ú-sí-ník-w-è ngù Jóhn.  
 banana SAGR-OM-give-PASS.TNS by John  
 intended: ‘The banana was given to him by John.’

We now turn to languages that lack indirect object passives, and thus predictably lack the DOMA: indirect objects in these languages can never block another argument from being the subject of the clause.

## 4.2 Languages with no indirect object passives

The source of the DOMA observed in §4.1 was proposed to be the fact that those languages move wh-indirect objects to Spec *vP* before direct objects are accessible for movement. As

a result, wh-indirect objects necessarily become the highest accessible argument to T, which blocks the direct object from raising to subject position. If a language somehow prevents the indirect object from being a viable subject of a passive, the DOMA is predicted not to arise because the direct object should then be the only accessible argument for promotion to subject position.

A review of some languages without indirect object passives confirms this prediction. Anagnostopoulou (2003) shows that Greek both lacks indirect object passives and lacks a restriction on direct object passivization when an indirect object wh-moves. Sundaresan (2020) shows the same result for Tamil and German. (71-72) show that the same is true for Turkish and Spanish (the (a) examples show the direct object passive as a baseline, the (b) examples show an ungrammatical indirect object passive, and the (c) examples show a grammatical direct object passive with a wh-moving indirect object)<sup>22</sup>.

(68) *Greek*

- a. To vivlio tis charistike (tis Marias).  
the book.NOM cl.GEN award.N-ACT the Maria.GEN  
'The book was awarded to Mary.' (Anagnostopoulou, 2003, ex. 33, p. 22)
- b. \*I Maria stalthike to grama.  
the Maria.NOM sent.N-ACT.3SG the letter.ACC  
intended: 'Mary was sent the letter.' (Anagnostopoulou, 2003, ex. 10a, p. 11)
- c. Tinos dhothike to vivlio?  
who.GEN gave.N-ACT.3SG the book.NOM  
'Who was the book given to?' (Anagnostopoulou, 2003, ex.308, p. 221)

(69) *Tamil*

- a. Andæ pustagam Sai-kkū kuḍūkka-paṭṭ-adū.  
that book.NOM Sai-DAT give-PASS-3NSG  
'That book was given to Sai.' (Sundaresan, 2020, ex. 1b, p. 15)
- b. \*Sai pustagatt-æ kuḍūkka-paṭṭ-aan.  
Sai book-ACC give-PASS-3MSG  
intended: 'Sai was given the book.' (Narayanan family, p.c.)
- c. Andæ pustagam jaar-ūkkū kuḍūkka-paṭṭ-adū?  
that book.NOM who-DAT give-PASS-3NSG  
'Who was that book given to?' (Sundaresan, 2020, ex. 2b, p. 15)

(70) *German* (Sundaresan, 2020)

- a. Der Kuchen wurde ihm gegeben.  
the.NOM cake was.PASS him.DAT given.PTCP  
'The cake was given to him.' (Felix Knollmann, p.c.)

---

<sup>22</sup>Tamil indirect objects don't wh-move overtly. As Sundaresan (2020) argues, however, Tamil wh-phrases still move covertly, on account of the lack of an intervention effect from the focus particle in (i).

- (i) Raman pustagatt-æ **maṭṭum jaar-ūkkū** kuḍū-tt-aan?  
Raman.NOM book-ACC only.FOC who-DAT give-PST-3MSG  
'Whom did Raman give only the book?' (Sundaresan, 2020, ex. 4, p. 16)

- b. \*Er wurde das Buch geschenkt.  
 he.NOM was the.ACC book gifted  
 intended: ‘He was given the book.’ (Felix Knollmann, p.c.)
- c. Wem wurde der Kuchen gegeben?  
 who.DAT was.PASS the.NOM cake given.PTCP  
 ‘Who was the cake given to?’ (Sundaresan, 2020, ex. 7, p. 16)

(71) *Turkish* (Öztürk family, p.c.)

- a. Ekmek Berke verildi.  
 bread.NOM Berk.DAT give.PASS.PST  
 ‘The bread was given to Berk.’
- b. \*Berk ekmeği verildi.  
 Berk.NOM bread.ACC give.PASS.PST  
 intended: ‘Berk was given the bread.’
- c. Kime ekmek verildi?  
 who.DAT bread.NOM give.PASS.PST  
 ‘Who was the bread given to?’

(72) *Spanish*

- a. Una casa le fue vendida a María.  
 a house cl.DAT was sold to Maria  
 ‘A house was sold to Maria.’ (Montalbetti, 1999, ex. 1b, p. 133)
- b. \*María fue vendida una casa.  
 Maria was sold a house  
 intended: ‘Maria was sold a house.’ (Montalbetti, 1999, ex. 1c, p. 133)
- c. A quién le fue vendida una casa?  
 to whom cl.DAT was sold a house  
 ‘To whom was a house sold?’ (Johannes Norheim, p.c.)

These languages all have in common that their indirect objects have overt morphology associated with them, such as inherent case in the first four languages and something that looks like a preposition in Spanish. If we assume that inherent case is actually a prepositional shell around the indirect object in these cases, then case marked indirect objects presumably cannot check the [*D*] feature on *v* or control  $\varphi$ -agreement on T. As a result, indirect objects in these languages cannot be subjects, and they cannot block other arguments from becoming subjects when they wh-move.

One might worry that the evidence in (68-72) is not enough to justify the present treatment of the DOMA, because I haven’t shown that these examples are actually double object constructions. If they can all be analyzed as prepositional dative constructions, then their lack of the DOMA might be attributable to the lack of the right structural context in which to observe it, rather than due to the morphosyntax of their indirect objects<sup>23</sup>.

<sup>23</sup>Italian is such a language which does not exhibit the DOMA, but may not have the right structural context in which to observe it. For more on Italian, see Appendix B.

This objection is not justified, however, because structural diagnostics support treating these examples as double object constructions. Greek has a clear dative alternation, where binding evidence supports the treatment of genitive indirect objects as in (68) as the higher internal argument of a double object construction. The Greek dative alternation is shown in (73), and binding data supporting the treatment of (73b) as a double object construction are shown in (74) (see Anagnostopoulou (2003) for additional support of this treatment).

(73) Greek dative alternation (Sabine Iatridou, p.c.)

- a. O Gianis estile [<sub>do</sub>to grama] [<sub>io</sub>**s-tin Maria**].  
 the Gianis.NOM sent.3SG the letter.ACC to-the Maria.ACC  
 ‘John sent the letter to Mary.’ *Prepositional dative construction*
- b. O Gianis estile [<sub>io</sub>**tis Marias**] [<sub>do</sub>to grama].  
 the Gianis.NOM sent.3SG the Maria.GEN the letter.ACC  
 ‘John sent Mary the letter.’ *Double object construction*

(74) Greek Principle A in double object constructions (Sabine Iatridou, p.c.)

- a. O Gianis edhikse tis Marias ton eafton tis s-ton kathrefti.  
 the Gianis.NOM showed the Maria.GEN the REFL.ACC GEN in-the mirror.ACC  
 ‘John showed Mary.gen herself in the mirror.’
- b. \*O Gianis edhikse tu eaftu tis tin Maria s-ton kathrefti.  
 the Gianis.NOM showed the REFL.GEN GEN the Maria.ACC in-the mirror.ACC  
 intended: ‘John showed herself.gen Mary in the mirror.’ (speaker comment: “extreme word salad”)

German and Turkish ditransitives are not typically considered to have a dative alternation, but binding evidence can still tell us the base generated order of internal arguments. Early evidence from Grewendorf (1988) suggested that the German double object construction generates direct objects in a higher position compared to indirect objects, as in the prepositional dative construction. However, two recent works argue against this conclusion.

First, Hallman (2021) has argued that German actually does have a productive dative alternation, but not all recipient-selecting verbs have it. For example, *geben* ‘to give’ and *schenken* ‘to gift’ only appear in the ‘double object construction’, while many other verbs, including the prefixed version *zurück-geben* ‘to give back’ have a prepositional variant as well.

(75) German dative alternation (Hallman, 2021, ex. 9, p. 149)

- a. weil ich [<sub>io</sub>Maria] [<sub>do</sub>die Briefe] weiter/zurück-gegeben habe  
 because I Maria(.DAT) the.ACC letters further/back-given have  
 ‘because I forwarded/gave back Maria the letters’ (Double object construction)
- b. weil ich [<sub>do</sub>die Briefe] [<sub>io</sub>**an** Maria] weiter/zurück-gegeben habe  
 because I the.ACC letters at Maria(.ACC) further/back-given have  
 ‘because I forwarded/gave back the letters to Maria’ (Prepositional dative construction)

Second, Twiner & Lee-Schoenfeld (2019) argue that controlling for additional factors such as case and agreement morphology on reflexives, and idiomatic readings of verbs like *show* reveals a different binding pattern than that originally introduced in Grewendorf (1988). They

argue, based on examples like (76) (and also others testing scope reconstruction effects) that the German double object construction is actually a double object construction – the indirect object is base generated higher than the direct object. The fact that German doesn't exhibit the DOMA is therefore not because German lacks the double object construction. I argue instead that German lacks the DOMA because its indirect object cannot be the subject of the passive of a double object construction. Based on similar binding data, Özkan (2013) argues that Turkish has a high applicative double object construction, making it similarly relevant for investigating the DOMA.

(76) Binding in German ditransitives: DAT binds ACC and not vice versa (Twiner & Lee-Schoenfeld, 2019, ex. 3b, p. 3, and subsequent prose)

- a. \*dass ich meinen Vater<sub>i</sub> zum Geburtstag sich<sub>i</sub> als Statue geschenkt habe  
that I my.ACC father for.the birthday REFL.DAT as statue given have  
intended: 'that I gave my dad himself as a statue for this birthday'
- b. dass ich meinem Vater<sub>i</sub> zum Geburtstag sich<sub>i</sub> als Statue geschenkt habe  
that I my.DAT father for.the birthday REFL.ACC as statue given have  
'that I gave my dad himself as a statue for this birthday'

Spanish ditransitives have no word order alternation, and their morphology looks like the prepositional dative construction. However, Demonte (1995) has shown that the presence or absence of clitic doubling in Spanish affects binding in ditransitives, which motivates the existence of a *structural* alternation in Spanish, despite there being no word order alternation in Spanish. Importantly, the presence of a clitic in (72) does not prevent the indirect object from wh-moving in the context of a direct object passive, showing that the Spanish double object construction does not exhibit the DOMA.

(77) Spanish clitic-doubled IOs are high; non-clitic-doubled IOs are low (Demonte, 1995, ex. 9, p. 10)

- a. El tratamiento psicoanalítico reintegró a María a sí-misma.  
the therapy psychoanalytic gave-back to Mary.DO to herself.IO  
'The psychoanalytic therapy helped Mary to be herself again.'
- b. \*El tratamiento psicoanalítico reintegró/devolvió a sí-misma a María.  
the therapy psychoanalytic gave-back to herself.DO to Mary.IO  
intended: 'The psychoanalytic therapy helped Mary to be herself again.'
- c. \*El tratamiento psicoanalítico **le** devolvió a María a la estima de  
the therapy psychoanalytic CL-DAT gave-back to Mary.DO to the esteem of  
sí-misma.  
herself.IO  
'The psychoanalytic therapy helped Mary to be herself again.'
- d. El tratamiento psicoanalítico **le** devolvió a la estima de sí-misma a  
the therapy psychoanalytic CL-DAT gave-back to the esteem of herself.DO to  
María.  
Mary.IO  
'The psychoanalytic therapy helped Mary to be herself again.'

Tamil also has a dative alternation – (69) is the double object construction, as evidenced by the dative marker *-kku* on the recipient instead of the preposition *kittæ*, which occurs in prepositional dative constructions. However, Sundaesan (2006) provides evidence from the distribution of dative in multiple contexts that while the prepositional variant of indirect objects must be low, dative indirect objects can be either high or low. As such, it is difficult to tell whether the examples in (69) can be derived from clauses where the indirect object is base generated higher than the direct object. Sundaesan (2020) nonetheless argues that Tamil is a true counterexample to the DOMA, though the binding data are needed to prove it concretely.

To summarize, we find that the inherent case marked indirect objects in Greek, Tamil, German, and Turkish, and the prepositional indirect objects in Spanish all move as PPs in *wh*-questions. They cannot raise to subject position in the passive, nor do they block a direct object passive when they *wh*-move through the edge of *vP*. For at least Greek, German, Spanish and Turkish, it is clear that the absence of the DOMA is not due to the lack of the right structural context – these languages have double object constructions, and they have direct object passives of double object constructions, which is the context in which we would expect to observe the DOMA. Tamil also potentially satisfies these criteria, but additional investigation is needed to be sure of the base positions of the internal arguments in the DOMA-less examples. The absence of the DOMA in those languages with double object constructions but without indirect object passives is expected on the present approach, given the morphosyntax of their indirect objects.

Thus far, I have shown that a number of languages with indirect object passives exhibit the DOMA, while a number of languages without indirect object passives do not. I proposed that the reason these two properties correlate (having IO passives and having the DOMA) is because *wh*-moving indirect objects can only block direct object passives if they can be subjects themselves. If a language otherwise permits indirect objects to raise to nominative, they necessarily have a way to *wh*-move indirect objects as DPs through Spec *vP* as well.

The morphology on the indirect object transparently tracks its movement prospects in every language that we have seen. Morphologically bare indirect objects that move behave like DPs in that they can A-move in passives and block other DPs when they *wh*-move. Overtly case-marked/prepositional indirect objects always behave like PPs, which cannot raise to subject position or interact with DPs in *wh*-movement.

### 4.3 Apparent counterexamples

As Holmberg et al. (2019) point out, there are also some symmetric languages, e.g. Kinyarwanda and Luganda, that do not exhibit the DOMA<sup>24</sup>. In (78a,79b), we see an indirect object that appears to *wh*-move as a DP, despite the fact that the clause is a direct object passive. This is surprising on the present account, because indirect object DPs are predicted to become the passive subject as they *wh*-move. In order for (78a,79b) to be good, the direct object would have to be raising to Spec *vP*/TP and controlling agreement despite the fact that the indirect object already did so.

---

<sup>24</sup>Apparently the Liverpool dialect of English also lacks the DOMA (Holmberg et al. (2019) fn. 6, citing Alison Biggs, p.c.). However, they suggest that the Liverpool dialect permits covert PPs in more places than other varieties of English, so the morphology may not be such a reliable indicator as to whether Liverpool English is a genuine counterexample.

- (78) *Kinyarwanda* no passive/wh-movement effect (Holmberg et al. 2019, ex. 64, p. 711 reporting from Jean Paul Ngoboka, p.c.)
- a. Abáana améézá a-záa-gur-ir-w-a (barasiinziiriye).  
2.children 6.tables 6SM-FUT-buy-APPL-PASS-FV  
'The children for whom the tables will be bought (are sleeping now).'
- b. Améézá abáana ba-záa-gur-ir-w-a (azaagera ku ishuúri ejó).  
6.tables 2.children 2SM-FUT-buy-APPL-PASS-FV  
'The tables that the children will be bought (will arrive at the school tomorrow).'
- (79) *Luganda* no passive/wh-movement effect (Holmberg et al., 2019, ex. 65, p. 711), ex. 65, p. 711
- a. N-jagala engoye abaana z-e ba-a-gul-ir-w-a.  
1SG.SM-want 10.clothes 2.children 10-REL 2SM-PST-buy-APPL-PASS-FV  
'I want the clothes that the children were bought.'
- b. N-jagala abaana engoye b-e z-a-gul-ir-w-a.  
1SG.SM-want 2.children 10.clothes 2-REL 10SM-PST-buy-APPL-PASS-FV  
'I want the children that the clothes were bought for.'

One of the parametric differences between Kinyarwanda/Luganda and the other Bantu languages under discussion is that Kinyarwanda/Luganda allow 1) multiple object markers, and 2) causative and applicative stacking.

- (80) *Zulu* only one object marker (Zeller, 2012, ex. 2b,c, p. 220)
- a. \*U-John u-**ba-zi**-nik-ile.  
1a-John 1SM-2OM-9OM-give-PFV
- b. \*U-John u-**zi-ba**-nik-ile.  
1a-John 1SM-9OM-2OM-give-PFV  
intended: 'John gave them them.'
- (81) *Kinyarwanda* multiple object markers, causative morphemes, and applicative morphemes (Holmberg et al. 2019, ex. 68, p. 713, citing Beaudoin-Lietz et al. 2004, 183)
- Umugoré  
1.woman  
a-ra-na-ha-ki-zi-ba-ku-n-someesheesherereza.  
1SM-DJ-also-16OM-7OM-10OM-2OM-2SG.OM-1SG.OM-read.CAUSE.CAUSE.APPL.APPL  
'The woman is also making us read it(book) with them(glasses) to you for me there(at the house).'

Several analyses treat facts like (81) (and others) as evidence that there is something special about either the Kinyarwanda verb phrase or its applicative morpheme. For example, McGinnis & Gerdtz (2004) propose that the Kinyarwanda applicative morpheme is a phase head, which licenses an additional specifier at its edge. Similarly, Zeller (2006) has argued that the Kinyarwanda verb phrase has an extra EPP feature that other languages lack. These extra specifier positions could be used to smuggle or leapfrog one argument past another within ApplP, before *v* is even merged. To capture such a move on the feature system outlined here,



the Kinyarwanda Appl head would either have to possess an additional feature to license this movement or more internal structure to license smuggling.

If the direct object can be smuggled or leapfrogged to the edge of ApplP, it would obviate the DOMA by being accessible for A-movement as early as or before the indirect object can wh-move to Spec *v*P. An early-moved direct object would become the outermost specifier of *v*P, promoting it to subject position, even in the presence of a wh-indirect object<sup>25</sup>.

## 5 Conclusion

In this paper, I examined the morphosyntax of object wh-questions in active and passive contexts in several languages. I argued that the profile of subject agreement that we find in every case is explainable by assuming a particular order of Merge and Move operations in the derivation. In active, transitive clauses, we saw that a requirement to Merge an external argument forced external Merge to precede wh-movement, or else wh-movement would bleed the external argument from getting introduced. This order of operations, combined with a tucking in condition on wh-movement, resulted in a structure where the transitive subject necessarily controls subject agreement. As a result, transitive object questions have the morphosyntax of regular transitive clauses in the languages that we have looked at.

In languages with symmetric passives, one might have thought that we could construct analogous passive examples to the active ones, where one argument of a double object construction wh-moves but another one becomes the passive subject. This profile of wh-questions is theoretically available given that these languages otherwise permit either object of a double object construction to be the subject of a passive. We saw, however, with evidence presented by Holmberg et al. (2019), that this was only the case if the *direct* object wh-moves. When the *indirect* object wh-moves, it necessarily becomes the subject of the clause. In other words, questions built from passives of double object constructions must look morphosyntactically like subject questions whenever the indirect object wh-moves, but not when the direct object wh-moves.

I argued that a smuggling approach to direct object passives, combined with a weak economy condition on feature-checking, accounts for this contrast. Since direct object passives are contingent on an intermediate step of VP-movement, but indirect object passives are not, the time at which indirect objects are considered for movement is earlier than the time at which direct objects may be considered for movement. Whereas in active transitive clauses, there was a possibility of merging the subject before wh-moving the object, in passives of double object constructions, I proposed that an economy condition would not permit VP-movement to precede wh-movement of the indirect object. As a result, direct object movement, which is contingent on VP-movement, cannot be ordered before indirect object wh-movement either, accounting for the DOMA.

Lastly, I argued that this approach has both empirical and conceptual advantages over Holmberg et al. (2019)'s proposal to restrict wh-movement. Their approach treated the DOMA

---

<sup>25</sup>Haya is like Luganda and Kinyarwanda in that it permits multiple object markers. It also doesn't exhibit the DOMA when both internal arguments agree in animacy (see pg. 68 of Duranti & Byarushengo (1977) for discussion). When the direct object is inanimate and the indirect object is animate, however, the DOMA reappears, which could provide insight into the nature of what kinds of features license extra EPP positions in different languages and contexts.

as an extrinsic Voice-related restriction on wh-movement, along the lines of Aldridge (2004) and Coon et al. (2014) for ergative extraction restrictions in Austronesian and Mayan languages respectively. While their approach has some theoretical motivation from those other phenomena, I argued that it made the wrong predictions for passives of double object constructions cross-linguistically. They predicted that *every* language with direct object passives of double object constructions should exhibit the DOMA, which was shown to be false for all of the languages in §4.2. On my proposal, all of those languages behave as predicted: their indirect objects cannot be passive subjects, and can therefore never bleed a direct object passive. The present theory therefore has greater empirical coverage, is more straightforwardly learnable, and does not require us to adopt additional constraints on wh-movement.

Looking ahead, we might wonder what other domains in language exhibit Weak Economy. van Urk & Richards (2015) argued that Multitasking in its original form was necessary to explain the profile of object movement in Dinka ditransitive questions. The present proposal has argued that ditransitive syntax involves a step of smuggling, however, in which case the present Weak Economy condition may better account for their data than the original Multitasking, which did not consider competition between wh-movement and VP-movement. However, a full re-analysis of their data would require an account of other language-specific properties of Dinka ditransitives, such as the V2-like nature of its object movement, which I leave to future research.

Outside of wh-movement in ditransitives, we expect Weak Economy to apply whenever a head has three features, and two elements are present which might jointly check them. Languages whose indirect objects control other operations like  $\varphi$ -agreement or clitic doubling are therefore good candidates for exhibiting Weak Economy (as we saw for Bantu object marking), assuming those other operations correspond to additional features on *v*. According to Weak Economy, an indirect object that can simultaneously control two operations on *v* should necessarily be targeted before smuggling takes place. Doing so might either block a direct object passive, or merely force a process involving the indirect object to precede direct object raising. This is speculation, but it provides a space of parametric variation across languages that can be tested.

## References

- Abels, Klaus. 2003. *Successive cyclicity, anti-locality, and adposition stranding*. Storrs, CT: University of Connecticut dissertation.
- Aldridge, Edith. 2004. *Ergativity and word order in Austronesian languages*. Ithaca, NY: Cornell University dissertation.
- Aldridge, Edith. 2008. Generative approaches to ergativity. *Language and Linguistics Compass: Syntax and Morphology* 2. 966–995.
- Anagnostopoulou, Elena. 2003. *The syntax of ditransitives: evidence from clitics*. New York, NY: Mouton de Gruyter.
- Anderssen, Merete, Yulia Rodina, Roksolana Mykhaylyk & Paula Fikkert. 2014. The acquisition of the dative alternation in Norwegian. *Language Acquisition* 21. 72–102. doi: 10.1080/10489223.2013.864296.

- Baker, Mark. 1988. *Incorporation: a theory of grammatical function changing*. University of Chicago Press.
- Beaudoin-Lietz, Christa, Derek Nurse & Sarah Rose. 2004. Pronominal object marking in Bantu. In Adkinbiyi Akinlabi & Oluseye Adesola (eds.), *Proceedings of the 4th World Congress of African Linguistics, New Brunswick 2003*. 175–188. Cologne: Rüdiger Köppe Verlag.
- Bittner, Maria & Ken Hale. 1996. The structural determination of case and agreement. *Linguistic Inquiry* 27. 1–68.
- Bošković, Željko. 2015. From the Complex NP Constraint to everything: on deep extractions across categories. *The Linguistic Review* 32. 603–669.
- Bošković, Željko. 2016. Getting really edgy: on the edge of the edge. *Linguistic Inquiry* 47. 1–33.
- Bowers, John. 2010. *Arguments as relations*. Cambridge, MA: The MIT Press.
- Branan, Kenyon & Michael Yoshitaka Erlewine. 2021. Locality and minimal search.
- Branan, Kenyon & Michael Yoshitaka Erlewine. 2022.  $\bar{A}$ -probing for the closest DP. *Linguistic Inquiry* 53. 1–56.
- Bruening, Benjamin. 2013. By phrases in passives and nominals. *Syntax* 16(1). 1–41.
- Cable, Seth. 2010. *The grammar of Q: Q-particles, wh-movement and pied-piping*. Oxford studies in comparative syntax: Oxford University Press.
- Caha, Pavel. 2009. *The nanosyntax of case*: University of Tromsø dissertation.
- Chomsky, Noam. 1981. *Lectures on government and binding*. Foris: Dordrecht.
- Chomsky, Noam. 1986. *Barriers*. MIT Press.
- Chomsky, Noam. 1995. *The minimalist program*. Cambridge, MA: MIT Press.
- Chomsky, Noam. 2001. Derivation by phase. In Michael Kenstowicz (ed.), *Ken hale: A life in language*, 1–52. Cambridge, MA: MIT Press.
- Chomsky, Noam. 2004. Beyond explanatory adequacy. In Adriana Belletti (ed.), *Structures and beyond*, Oxford University Press.
- Collins, Chris. 2005. A smuggling approach to the passive in English. *Syntax* 8(2). 81–120.
- Coon, Jessica, Nico Baier & Theodore Levin. 2021. Mayan Agent Focus and the Ergative Extraction Constraint: Facts and fictions revisited. *Language* 97(2). 269–332.
- Coon, Jessica, Pedro Mateo Pedro & Omer Preminger. 2014. The role of case in  $\bar{A}$  extraction asymmetries. *Linguistic Variation* 14(2). 179–242.

- Creissels, Denis. 2002. Valence verbale et voix en Tswana. *Bulletin de la Société de Linguistique de Paris* 97. 371–426.
- De Guzman, Videa P. 1987. Indirect objects in SiSwati. *Studies in African Linguistics* 18(3). 309–325.
- Demonte, Violeta. 1995. Dative alternation in Spanish. *Probus* 7(1). 5–30.
- Duranti, Alessandro & Ernest R. Byarushengo. 1977. On the notion of “direct object”. In Ernest R. Byarushengo, Alessandro Duranti & Larry M. Hyman (eds.), *Haya grammatical structure*, 45–71. Los Angeles: University of Southern California, Department of Linguistics.
- Engdahl, Elisabet & Anu Laanemets. 2015. Prepositional passives in Danish, Norwegian and Swedish: a corpus study. *Nordic Journal of Linguistics* 38(3). 285–337.
- Grewendorf, Günther. 1988. *Aspekte der deutschen Syntax*. Tübingen: Narr.
- Haddican, William & Anders Holmberg. 2015. Four kinds of object asymmetry. In Ludmila Veselovská & Markéta Janebová (eds.), *Complex visibles out there: proceedings of the Olomouc linguistics colloquium 2014: Language use and linguistic structure*. 145–162. Palacký University, Olomouc.
- Hallman, Peter. 2021. Explaining Siewierska’s generalization. *The Journal of Comparative Germanic Linguistics* 24. 145–184.
- Halpert, Claire. 2012. *Argument licensing and agreement in Zulu*: MIT dissertation.
- Harizanov, Boris & Vera Gribova. 2019. Whither head movement? *Natural Language & Linguistic Theory* 37(2). 461–522.
- Harley, Heidi. 1995. *Subjects, events and licensing*: MIT dissertation.
- Harley, Heidi. 2011. A minimalist approach to argument structure. *The Oxford Handbook of Linguistic Minimalism*.
- Heck, Fabian. 2008. *On pied-piping*. De Gruyter Mouton.
- Holmberg, Anders, Michelle Sheehan & Jenneke van der Wal. 2019. Movement from the double object construction is not fully symmetrical. *Linguistic Inquiry* 50(4). 677–721.
- Iorio, David. 2014. *Subject and object marking in Bembe*: Newcastle University dissertation.
- Kratzer, A. 1996. Severing the external argument from its verb. In J. Rooryck & L. Zaring (eds.), *Phrase structure and the lexicon*, 109–137. Kluwer Academic Publishers, Dordrecht.
- Lamontagne, Greg & Lisa Travis. 1987. The syntax of adjacency. In *Proceedings of WCCFL 6*. 173–186.
- Larson, Richard. 1988. On the double object construction. *Linguistic Inquiry* 19. 335–392.
- Legate, Julie Anne. 2003. Some interface properties of the phase. *Linguistic Inquiry* 34(3). 506–516.

- Legate, Julie Anne. 2014. *Voice and v: Lessons from Acehnese*, vol. 69. MIT Press.
- Levin, Theodore. 2015. *Licensing without case*. Cambridge, MA: MIT dissertation.
- Longenbaugh, N. 2017. Composite A/ $\bar{A}$ -movement: evidence from English tough movement. <http://ling.auf.net/lingbuzz/003604>.
- Longenbaugh, Nicholas. 2019. *On expletives and the agreement-movement correlation*. Cambridge, MA: MIT dissertation.
- Marantz, Alec. 1993. Implications of asymmetries in double object constructions. In Sam A. Mchombo (ed.), *Theoretical aspects of Bantu grammar 1*, 113–151. Stanford, Calif.: CSLI Publications.
- Matushansky, Ora. 2006. Head Movement in Linguistic Theory. *Linguistic Inquiry* 37(1). 69–109.
- May, R. 1979. Must COMP-to-COMP movement be stipulated? *Linguistic Inquiry* 10(4). 719–725.
- McGinnis, Martha. 2001a. Phases and the syntax of applicatives. In Minjoo Kim & Uri Strauss (eds.), *NELS 31*. 333–349. Amherst: University of Massachusetts, GLSA.
- McGinnis, Martha. 2001b. Variation in the phase structure of applicatives. *Linguistic Variation Yearbook 1* 105–146.
- McGinnis, Martha & Donna B. Gerdts. 2004. A phase-theoretic analysis of Kinyarwanda multiple applicatives. In Sophie Burelle & Stanca Somesfalean (eds.), *Proceedings of the 2003 CLA Annula conference*. 154–165.
- Merchant, Jason. 2013. Voice and ellipsis. *Linguistic Inquiry* 44(1). 77–108.
- Mills, Jullian Louise. 2008. *Non-specific objects in the pseudopassive: the syntax and semantics of English pseudo-incorporated pseudopassives*. <https://dspace.mit.edu/handle/1721.1/45956>: MIT MA thesis.
- Montalbetti, Mario. 1999. Spanish passivized datives: the relevance of misanalysis. In Kyle Johnson & Ian Roberts (eds.), *Beyond principles and parameters*, Dordrecht: Kluwer.
- Morolong, Malillo & Larry M. Hyman. 1977. Animacy, objects and clitics in Sesotho. *Studies in African Linguistics* 8. 199–218.
- Müller, G. 2010. On deriving CED effects from the PIC. *Linguistic Inquiry* 41(1). 35–82.
- Neeleman, A. & H. Van De Koot. 2010. A local encoding of syntactic dependencies and its consequences for the theory of movement. *Syntax* 13(4). 331–372.
- Neeleman, Ad & Fred Weerman. 1999. *Flexible syntax: A theory of case and arguments*. Dordrecht: Kluwer.
- Newman, Elise. 2021. *The (in)distinction between wh-movement and c-selection*: MIT dissertation.

- Oehrle, Richard T. 1976. *The grammatical status of the English dative alternation*. Cambridge, MA: MIT dissertation.
- Özkan, Sözen. 2013. *The syntax of multiple internal arguments in Turkish*. <https://surface.syr.edu/thesis/1>: Syracuse University MA thesis.
- Pesetsky, David. 1995. *Zero syntax*. Cambridge, MA: The MIT Press.
- Pesetsky, David. 2013. *Russian case morphology and the syntactic categories*. The MIT Press.
- Pesetsky, David & Esther Torrego. 2001. T-to-C movement: Causes and consequences. In Michael Kenstowicz (ed.), *Ken Hale: A life in language*, 355–426. Cambridge, MA: MIT Press.
- Preminger, Omer. 2014. *Agreement and its failures*. The MIT Press.
- Pylkkänen, Liina. 2008. *Introducing arguments*. The MIT Press.
- Ramchand, Gillian Catriona. 2008. *Verb meaning and the lexicon: a first-phase syntax*. Cambridge University Press.
- Rezac, Milan. 2008. What will you have, DP or NP? In Daniel Harbour, David Adger & Susana Béjar (eds.), *Phi theory: Phi-features across modules and interfaces*, 83–129. Oxford: Oxford University Press.
- Rezac, Milan. 2013. Case and licensing: evidence from ECM+DOC. *Linguistic Inquiry* 44(2). 299–319.
- Richards, Norvin. 1997. *What moves where when in which language?* Cambridge, MA: MIT dissertation.
- Rizzi, L. 1990. *Relativized minimality*. Cambridge, MA: MIT Press.
- Sauerland, Uli. 2003. Intermediate adjunction with A-movement. *Linguistic Inquiry* 34(2). 308–313.
- Schäfer, Florian & Marcel Pitteroff. 2017. Implicit external arguments in passives: against syntactic projection. In *Conference on interdisciplinary approaches to linguistic theory*, vol. 1. 6–8.
- Sundaresan, Sandhya. 2006. The argument structure of verbal alternations in Tamil. In Donald Baumer, David Montero & Michael Scanlon (eds.), *Proceedings of the 25th West Coast Conference on Formal Linguistics*. 390–398. Cascadilla Proceedings Project, Somerville, MA, USA.
- Sundaresan, Sandhya. 2020. A curious A/ $\bar{A}$  non-interaction in Tamil double-object constructions. *Snippets* 38.
- Twiner, Nicholas & Vera Lee-Schoenfeld. 2019. Binding German (in)direct objects: Spell-out strategies for disambiguation. In *Proc Ling Soc Amer*, vol. 35. 1–15. <https://doi.org/10.3765/plsa.v4i1.4534>.

- van der Wal, Jenneke. 2015. Bantu object clitics as defective goals. *Revue Roumaine de Linguistique* 60. 277–296.
- Van Otterloo, Roger. 2011. *The Kifuliiru language. vol. 2, a descriptive grammar*. Dallas, TX: SIL International.
- van Urk, Coppe. 2015. *A uniform syntax for phrasal movement: A case study of Dinka Bor*. Cambridge, MA: MIT dissertation.
- van Urk, Coppe & Norvin Richards. 2015. Two components of long-distance extraction: Successive cyclicity in Dinka. *Linguistic Inquiry* 46(1). 113–155.
- Visser, Marianna. 1986. Cliticization and case theory in Xhosa. *South African Journal of African Languages* 6. 129–137.
- Williams, Edwin. 2003. *Representation theory*. MIT Press.
- Williams, Edwin. 2011. *Regimes of derivation in syntax and morphology*. Taylor & Francis.
- Williams, Edwin. 2013. Generative semantics, generative morphosyntax. *Syntax* 16(1). 77–108.
- Woolford, Ellen. 1995. Why passive can block object marking. In Akinbiyi Akinlabi (ed.), *Theoretical approaches to African linguistics*, 199–215. Trenton, NJ: Africa World Press.
- Zeller, J. 2006. Agreement and the EPP in Kinyarwanda applicatives. In P. Brandt & E. Fuß (eds.), *Form, structure and grammar*, vol. 275–295, Akademie-Verlag.
- Zeller, Jochen. 2012. Object marking in isiZulu. *Southern African Linguistics and Applied Language Studies* 30. 219–235.

## A Some additional notes on feature-checking

### A.1 A note on improper movement

One might worry that indirect object passive questions, on this view, violate the ban on improper movement: the indirect object A-moves to subject position after first wh-moving (and A-moving) to Spec *v*P. As (Longenbaugh, 2017, fn.8) notes, such mixed movement to Spec *v*P, followed by A-movement to Spec TP, is not actually expected to violate the ban on improper movement, according to two leading analyses of the ban. Neeleman & Koot (2010), following May (1979), suggest that improper movement is ruled out due to chain resolution issues:  $\bar{A}$ -moving phrases behave as though they are in the lowest position in the chain, while A-moving phrases behave as though they are in the highest position in the chain. Mixed movement should have both options, meaning that an option exists which looks to the interfaces like successive A-movement, rather than improper movement. Williams (2003, 2011, 2013) offers another view of improper movement, which includes a representational constraint that is also not violated in (6). On his view, movement cannot target a lower projection in the functional hierarchy (i.e. movement to a matrix TP from an embedded CP because is ruled out because TP is lower on the functional hierarchy). Since neither of these principles rule out the derivation in (6),

I assume that the movement proposed here does not necessarily violate the ban on improper movement.

## A.2 Feature-checking and the functional hierarchy

We have seen that unchecked selectional features can license movement in two kinds of scenarios: 1) when no external argument is merged in response to the selectional feature  $[\cdot D \cdot]$  on  $v$ , raising to that position becomes possible (as in a passive), and 2) the unchecked  $[\cdot V \cdot]$  on  $v$  is proposed to license smuggling when VP is not merged as  $v$ 's complement.

As a reviewer notes, this idea makes general predictions about clause structure, which should be tested – are there other scenarios where some unchecked category feature licenses movement when it is not satisfied by external Merge? For example, we could imagine the same kinds of scenarios arising higher in the clause: if T normally selects for AspP, but negation intervenes, then do we expect AspP to raise to Spec TP?

It is important to remember that the predictions of the theory depend entirely on the proposed features for these heads. The first question we would need to answer, in order to know whether AspP smuggling exists, is whether T selects for AspP. If we imagine that T always selects for a polarity head of some kind, and never merges directly with aspect, then we would have no reason to posit a selectional feature on T that would license smuggling of AspP to Spec TP. By contrast, if we did have reason to think that T sometimes selects for Pol and sometimes for Asp, then we expect AspP to raise in the context of Pol. Future research on the TAM domain should decide which of these two proposals is appropriate. See Newman (2021) for additional discussion of this logic in the domain of argument selection.

## A.3 More on head movement

One might wonder, if all Merge/Move is assumed to be feature-driven, whether head movement must therefore also be feature-driven. Though further work is needed to develop a complete theory of head movement in the present system, feature-driven Merge is consistent with the view of head movement outlined in Harizanov & Gribanova (2019).

Recall that on their view, the term “head movement” refers to two distinct phenomena: 1) internal Merge in the syntax, followed by morphological fusion, vs. 2) a post-syntactic word-building process. They suggest that the first type of head movement behaves like other kinds of internal Merge, which can skip intermediate head positions. By contrast, the second type of head movement obeys the head movement constraint (HMC).

If all internal Merge is feature-driven, the fact that the first kind of head movement violates the HMC is straightforwardly predicted by Anti-locality. If VP checks a  $[\cdot V \cdot]$  feature on  $v$  via complementation, there is no remaining  $[\cdot V \cdot]$  feature on  $v$  to attract head movement of V to  $v$ . Thus, head movement that occurs in the syntax would have to violate the HMC. For V and  $v$  to ever form a complex head, on this view, post-syntactic movement is required (either post-syntactic movement from V to  $v$ , or if V moved in the syntax to a higher head, post-syntactic movement of  $v$  to that higher head), as suggested by Harizanov & Gribanova (2019).



## B Italian

Binding evidence in (82) shows that the indirect object is always low in Italian ditransitives. It is therefore not clear whether Italian has a genuine double object construction, which would feed indirect object passivization in the first place. As expected, Italian does not exhibit the DOMA in (83).

(82) Binding in Italian ditransitives (Holmberg et al., 2019, ex. 53, p. 704)

a. L'ispezione ha mostrato ogni imperfezione<sub>i</sub> al suo<sub>i</sub> responsabile.  
the.inspection has shown each imperfection to.the its responsible  
'The inspection showed each imperfection to the person responsible.'

b. \*L'ispezione ha mostrato le sue<sub>i</sub> imperfezioni a ogni professore<sub>i</sub>.  
the.inspection has shown the.PL POSS.3SG.FPL imperfection to each teacher  
intended: 'The inspection showed each teacher his/her own imperfections.'

(83) *Italian* (adapted from Holmberg et al. 2019, p. 702-3, verified with Enrico Flor and Giovanni Roversi, p.c.)

a. Questi libri sono stati dati a Maria.  
these.MPL books are been.MPL given.MPL to Maria  
'These books were given to Maria.'

b. \*Maria è stata data un regalo.  
Maria is been.FSG given.FSG a present  
intended: 'Maria was given a present.' (Enrico Flor, p.c.)

c. A chi è stato dato questo libro?  
to who is been.MSG given.MSG this.MSG book  
'To whom was this book given?'

Despite binding evidence indicating a single structural description for Italian ditransitives, Holmberg et al. (2019) propose that Italian has two kinds of ditransitive structures, one of which is the “double object construction” and the other of which is the “prepositional dative construction” (both of which place the direct object structurally higher than the indirect object, to account for binding). They propose that the lack of the DOMA in (83c) is misleading, and that Italian “double object constructions” really do exhibit an interaction if we work hard enough to control the examples. They use the animacy of the subject to distinguish the two constructions from each other (following Oehrle 1976): inanimate subjects correspond to the “double object construction” while animate subjects ambiguously correspond to the either the “double object construction” or the “prepositional dative construction” (84).

(84) English double objects but not prepositional datives permit inanimate subjects

- a. The book gave me an idea.
- b. \*The book gave an idea to me.

In Italian, a direct object passive is possible irrespective of the animacy of the *by*-phrase (85), indicating that a passive of a “double object construction” is possible. Wh-movement of an indirect object is likewise insensitive to the animacy of the subject (86).

- (85) *Italian* DO-passives (Holmberg et al., 2019, ex. 48, p. 702)
- a. Questi libri sono stati dati a Maria dal professore.  
these.MPL books are been.MPL given.MPL to Maria by.the teacher  
'These books were given to Maria by the teacher.'
  - b. Queste idee sono state date a Maria da questo libro.  
these.FPL ideas are been.FPL given.FPL to Maria by this book  
'These ideas were given to Maria by this book.'

- (86) *Italian* IO-wh-movement (Holmberg et al., 2019, ex. 49, p. 702)
- a. A chi darà un regalo Maria?  
to who give.3SG.FUT a.MSG present Maria  
'Who will Maria give a present to?'
  - b. A chi ha insegnato qualcosa di importante la prima relazione?  
to who has taught something of important the first relationship  
'Who has his/her first relationship taught something important to?'

Holmberg et al. (2019) argue that combining passive and wh-movement, however, *is* sensitive to the animacy of the *by*-phrase. It is somewhat difficult to show this, given that adding an overt *by*-phrase to either of the examples in (87) degrades the sentences substantially (for some reason). In order to see a stronger contrast, they try topicalizing the passivized argument, which apparently improves the sentence when the *by*-phrase is animate but not when it is inanimate.

- (87) *Italian*: DO-passive in IO-wh-movement sensitive to the presence of a *by*-phrase (Holmberg et al., 2019, ex. 50b,51a, p. 703)
- a. \*A chi è stato insegnato qualcosa di importante dalla sua prima relazione?  
to who is been.MSG taught.MSG something of important by.the POSS.3SG first relationship  
intended: 'To whom was something important taught by his/her first relationship?'
  - b. ??A chi è stato dato questo libro dal professore?  
to who is been.MSG given.MSG this.MSG book by.the teacher  
intended: 'To whom was this book given by the teacher?'
- (88) *Italian*: animacy effects observable in topicalized versions (Holmberg et al., 2019, ex. 50a,51c,fn 25, p. 703)
- a. \*Alcune idee, a chi saranno date da questo libro?  
some.FPL ideas.FPL to who be.3PL.FUT given.FPL by this book  
intended: 'Some ideas, to whom were given by this book?'
  - b. Questo libro, a chi è stato dato dal professore?  
this.MSG book to who is been.MSG given.MSG by.the teacher  
'This book, to whom was given by the teacher?'

They conclude that it is possible to wh-move an indirect object in a passive, *only* if the *by*-phrase has an animate argument. Since the prepositional dative construction has a requirement for an animate agent but a double object construction does not, they argue that the Italian

“double object construction” shows the DOMA, despite the fact that Italian lacks indirect object passives.

While I have no account for the ungrammaticality of (88a), their conclusion that the animacy of the *by*-phrase leads to its ungrammaticality is not supported by the intuitions of speakers that I have consulted. I have verified with two speakers (Enrico Flor and Giovanni Roversi) that removing the *by*-phrase makes (88a) good, *even* in a context where it is clear that the teacher is inanimate.<sup>26</sup> For example, (89) could be uttered at the end of a TV show about dating to invite speculation about who learned from their relationships. I confirmed that the covert *by*-phrase is understood to be *dalla sua prima relazione*, and the example is good.

- (89) A chi è stato insegnato qualcosa di importante?  
to who is been.MSG taught.MSG something of important  
‘To whom was something important taught?’ (understood teacher = their first relationship; Enrico Flor, Giovanni Roversi, p.c.)

While the contrast in (88) is certainly puzzling, the meanings of arguments are known to occasionally affect processes that we otherwise view as productive, and our analyses of such facts need not posit structural ambiguity. I therefore propose that something else accounts for the contrast in (88), though I leave investigation of that independent factor to future research. Thus, I conclude that (88) is not evidence that Italian “double object constructions” show the passivization/wh-movement interaction observed in the symmetric languages of §4.1.

---

<sup>26</sup>Holmberg et al.’s speakers also confirm that removing the *by*-phrase improves the sentences in (87), though it is not clear whether the contexts are controlled to account for the understood agent/causer.